

# IMPORTANT INSTRUCTIONS

---

## GAS COMPRESSORS



*Solutions beyond products...*

**CORKEN**<sup>®</sup>  
**IDEX**

Warning: (1) Periodic inspection and maintenance of Corken products is essential. (2) Inspection, maintenance and installation of Corken products must be made only by experienced, trained and qualified personnel. (3) Maintenance, use and installation of Corken products must comply with Corken instructions, applicable laws and safety standards (such as NFPA Pamphlet 58 for LP-Gas and ANSI K61. 1-1972 for Anhydrous Ammonia). (4) Transfer of toxic, dangerous, flammable or explosive substances using Corken products is at user's risk and equipment should be operated only by qualified personnel according to applicable laws and safety standards.

## **WARNING**

Install, use and maintain this equipment according to CORKEN's instructions and all applicable federal, state, local laws and codes. Periodic inspection and maintenance is essential.

## **CORKEN ONE YEAR LIMITED WARRANTY**

CORKEN, INC. warrants that its products will be free from defects in material and workmanship for a period of 12 months following date of purchase from CORKEN. CORKEN products which fail within the warranty period due to defects in material or workmanship will be repaired or replaced at CORKEN's option, when returned, freight prepaid to: CORKEN, INC., 3805 N.W. 36th Street, Oklahoma City, Oklahoma 73112. Parts subject to wear or abuse, such as mechanical seals, blades, piston rings, valves, and packing, and other parts showing signs of abuse are not covered by this limited warranty. Also, equipment, parts and accessories not manufactured by CORKEN but furnished with CORKEN products are not covered by this limited warranty and purchaser must look to the original manufacturer's warranty, if any. This limited warranty is void if the CORKEN product has been altered or repaired without the consent of Corken. All implied warranties, including any implied warranty of merchantability or expressed warranty period. CORKEN DISCLAIMS ANY LIABILITY FOR CONSEQUENTIAL DAMAGES DUE TO BREACH OF ANY WRITTEN OR IMPLIED WARRANTY ON CORKEN PRODUCTS. Transfer of toxic, dangerous, flammable or explosive substances using CORKEN products is at the user's risk. Such substances should be handled by experienced, trained personnel in compliance with governmental and industrial safety standards.

## **CONTACTING THE FACTORY**

Before you contact the factory, note the Model Number and Serial Number of your pump. The Serial Number directs us to a file containing all information on material specifications and test data applying to your specific pump. When ordering parts, the CORKEN Service Manual should be consulted for the proper Part Numbers. ALWAYS INCLUDE THE MODEL NUMBER AND SERIAL NUMBER WHEN ORDERING PARTS.

The Model and Serial Numbers are shown on the nameplate of the unit. Record this information for future reference.

Model No. \_\_\_\_\_

Serial No. \_\_\_\_\_

Date Purchased \_\_\_\_\_

Date Installed \_\_\_\_\_

Purchased From \_\_\_\_\_

Installed By \_\_\_\_\_

### **IMPORTANT NOTE TO CUSTOMERS!**

**CORKEN, INC. does not recommend ordering parts from general descriptions in this manual. To minimize the possibility of receiving incorrect parts for your machine, Corken strongly recommends you order parts according to part numbers in the Corken Service Manual. If you do not have the appropriate service manual pages, call or write Corken with model number and serial number from the nameplate on your compressor.**

TABLE OF CONTENTS

<b>1. HOW YOUR CORKEN COMPRESSOR WORKS . . . . .</b>	<b>PAGE 1</b>
Why Corken Compressors are Special . . . . .	1
Running Gear . . . . .	2
Piston Rod Packing / Distance Pieces. . . . .	3
Pistons / Piston Rings . . . . .	4
Valves . . . . .	4
Cooling . . . . .	4
Suction Valve Unloaders . . . . .	4
Cylinder Lubricators. . . . .	7
<b>2. INSTALLING YOUR CORKEN COMPRESSOR . . . . .</b>	<b>PAGE 9</b>
Location . . . . .	9
Foundation . . . . .	9
Piping . . . . .	9
Liquid Traps . . . . .	10
Driver Installation / Flywheels . . . . .	12
Crankcase Lubrication . . . . .	12
Cooling Water . . . . .	13
Wiring . . . . .	13
Shutdown / Alarm Devices . . . . .	14
Purging and Draining of Distance Piece . . . . .	14
Relief Valves . . . . .	14
Cylinder Lubricators (Lubricated Models Only) . . . . .	16
<b>3. START-UP OF YOUR CORKEN COMPRESSOR . . . . .</b>	<b>PAGE 18</b>
Inspection After Extended Storage . . . . .	18
Flywheel and V-belt Alignment. . . . .	18
Crankcase Oil Pressure Adjustment . . . . .	19
Adjustment of Mechanical Unloader Controls. . . . .	19
Startup Checklist . . . . .	21
<b>4. ROUTINE MAINTENANCE CHART . . . . .</b>	<b>22</b>
<b>5. ROUTINE SERVICE AND REPAIR PROCEDURES . . . . .</b>	<b>23</b>
Valves . . . . .	23
Cylinder and Head . . . . .	26
Piston Rings and Piston Ring Expanders . . . . .	26
Piston Replacement . . . . .	26
Piston Rod Packing Adjustment . . . . .	27
Bearing Replacement . . . . .	27
Wrist Pin Bushing Replacement . . . . .	28
Connecting Rod Bearings . . . . .	28
Roller Bearings. . . . .	28
Oil Pump Inspection. . . . .	29
<b>6. EXTENDED STORAGE PROCEDURES . . . . .</b>	<b>PAGE 30</b>
<b>7. INSTALLATION OF LIQUID GAS TRANSFER COMPRESSORS. . . . .</b>	<b>PAGE 31</b>
Stationary Compressors . . . . .	31
Truck Mounted Compressors. . . . .	35
<b>APPENDIX</b>	
A. Model Number and Mounting Identification Code . . . . .	37
B. Material Specifications. . . . .	38
C. Mechanical Specifications . . . . .	39
D. Bolt Torque Values. . . . .	40
E. Clearance and Dimensions . . . . .	42
F. Purging, Drawing and Rod Packing . . . . .	43
G. Compressor Trouble Shooting . . . . .	44
H. Compressor Log Sheet . . . . .	45

**CROSS SECTION OF A TYPICAL CORKEN OIL-FREE VERTICAL COMPRESSOR**

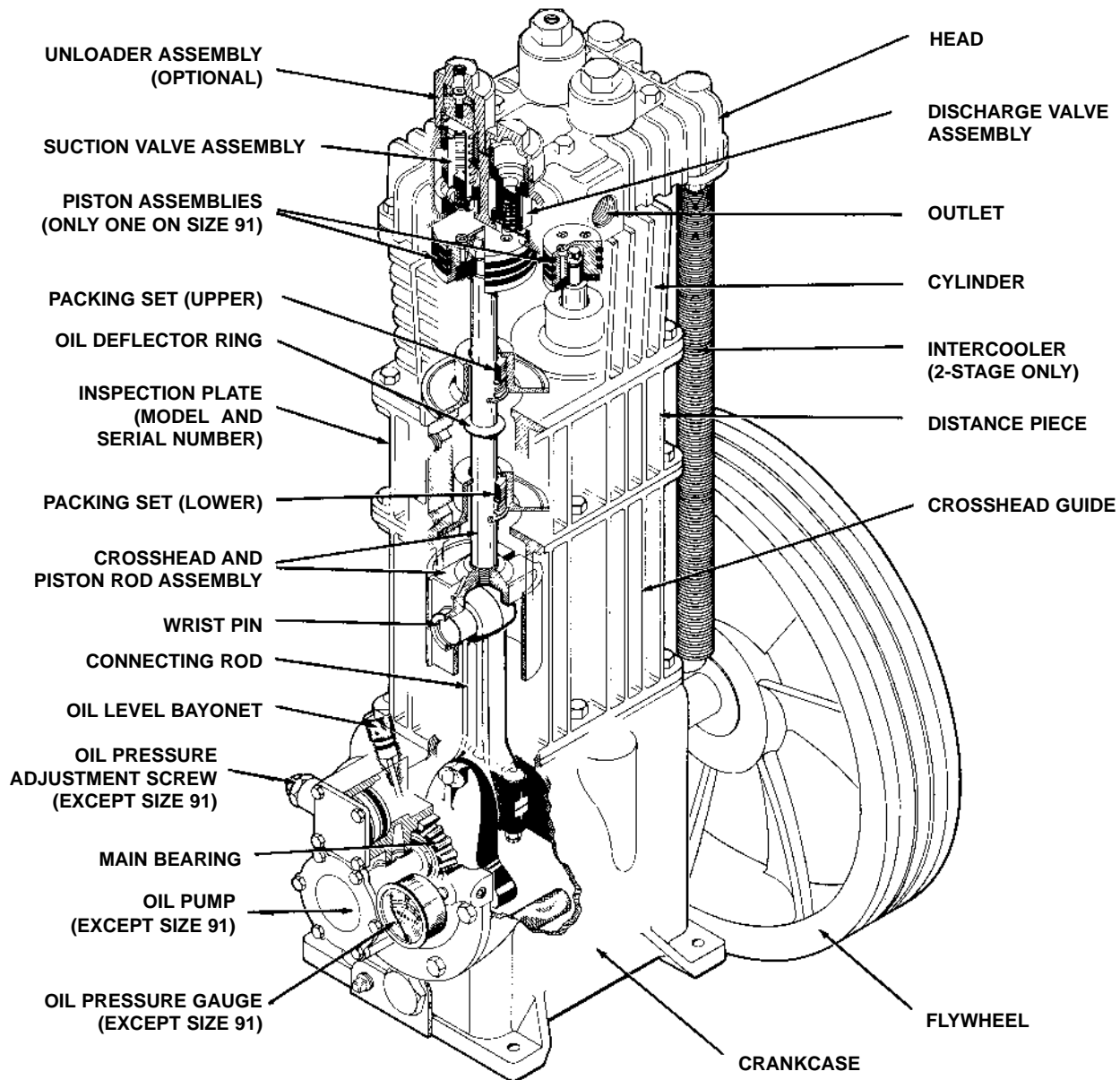

**FIGURE 1.1A**

**1.1 WHY CORKEN COMPRESSORS ARE SPECIAL**

Corken industrial gas compressors are unique among compressors their size. Unlike ordinary lubricated gas compressors, Corken compressors completely isolate the pressurized gas in the

compression chamber from the crankcase. While piston rings seal the piston tightly enough for it to do compression work, they do not provide enough sealing to isolate the compression chamber from the crankcase. To further seat the compression chamber, a crosshead/piston rod design with seals around the piston rod is required (see Figure 1.1A).

By utilizing specialized piston-rod sealing systems, Corken compressors can compress pressurized, flammable and toxic gases. It is also used to compress harmless gases where oil-free compression or elevated suction pressures are required. With numerous design options available, Corken offers the most versatile line of small gas compressors in the world.

NOTE: To confirm the options provided with your machine, check the model number on your compressor's nameplate against the chart in Appendix A.



## 1.2 RUNNING GEAR

Corken gas compressors are mounted on sturdy oil-lubricated crankcases. Crankshafts are supported by heavy-duty roller bearings. The connecting rods ride the crankshaft on journal bearings. With the exception of the small Size 91 compressor, all compressor crankcases are pressure lubricated. An automatically reversible gear-type oil pump circulates oil through passages drilled in the crankshaft and connecting rod to lubricate journal bearings and wrist pins (see Figure 1.2A). Sturdy iron crossheads transmit reciprocating motion to the piston.

Corken's automatically reversible oil pump design allows the machine to function smoothly in either direction of rotation.

A replaceable 10-micron spin-on oil filter ensures long life.

### PRESSURE LUBRICATION SYSTEM

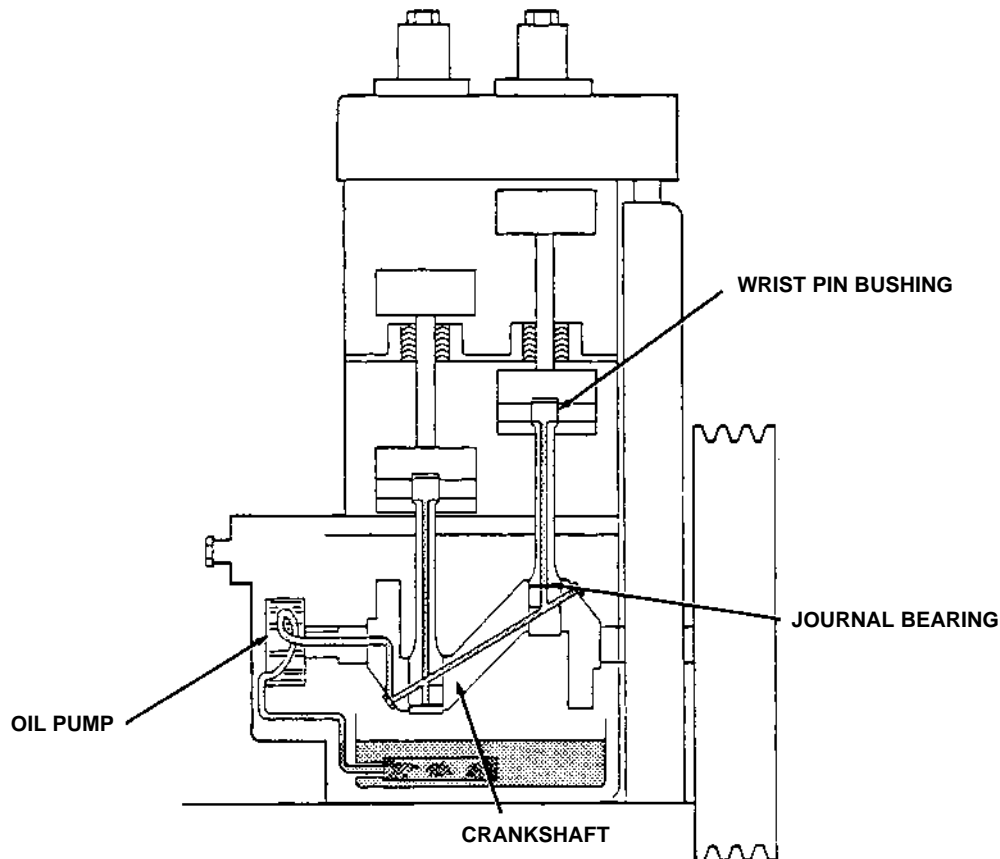
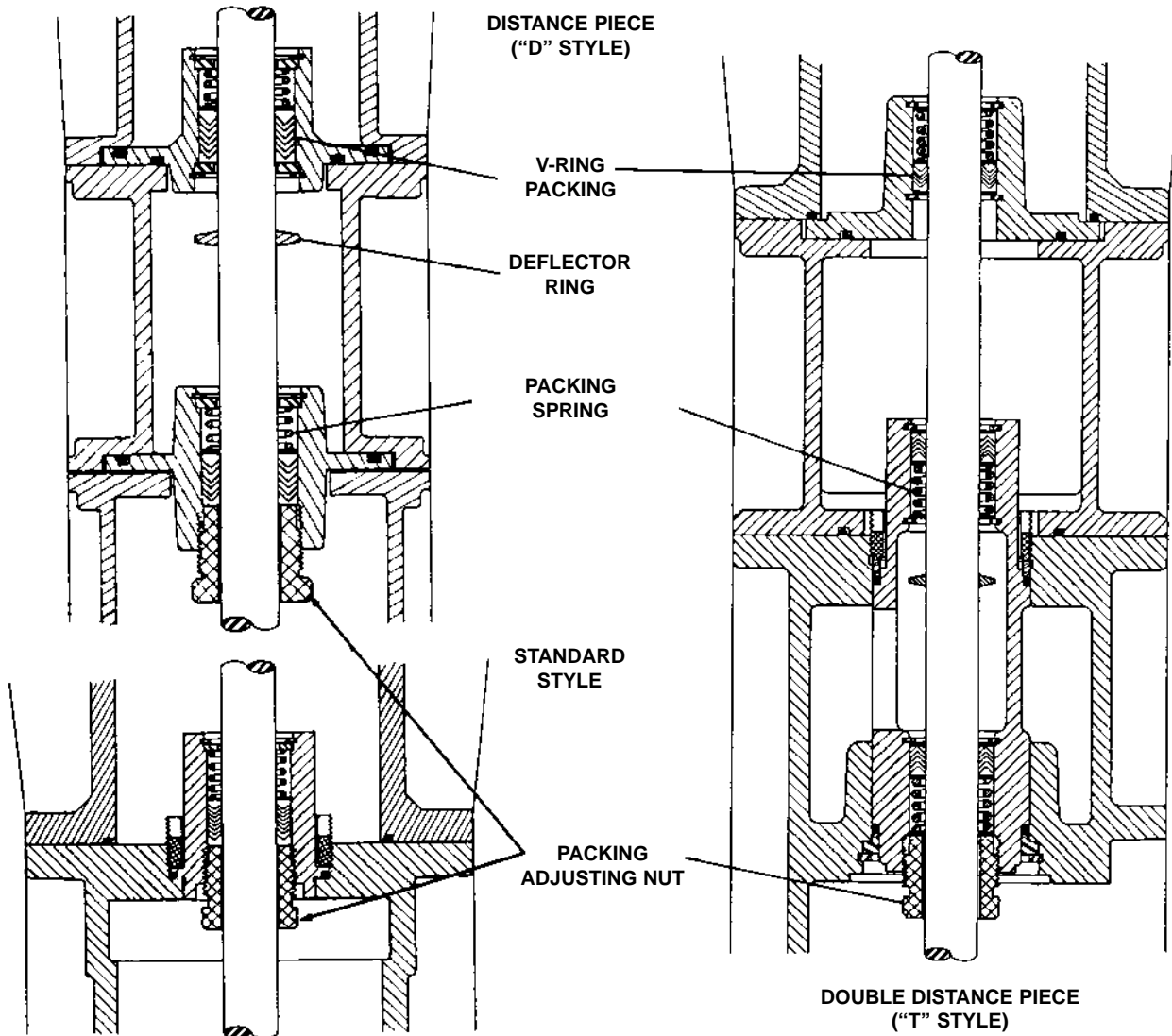

FIGURE 1.2A

**COMPARISON OF DIFFERENT COMPRESSOR SEALING SYSTEMS**



**FIGURE 1.3A**

**1.3 PISTON ROD PACKING / DISTANCE PIECES**

Piston rod packing seals gas into the compression chamber and prevents seepage of oil out of the crankcase into the compressor cylinder. The packing consists of several PTFE V-rings sandwiched between a male and female ring (see Figure 1.3A). The packing rings are spring loaded to allow a small amount of "float" to alleviate cyclic stresses, reduce wear, and assure a positive seal.

Corken manufactures compressors with one, two, or three packing sets. Standard-style units contain one packing set. For completely oil-free compression, two packing sets are used (see Figure 1.3A); oil-free

compressors are designated by the prefix "D". Oil that seeps past the first packing set is prevented from reaching the second by an oil deflector ring. Three packing sets and two distance pieces are available on special machines for compressing highly corrosive gases. Units with three packing sets are designated by the prefix "T". The construction of the "D"- and "T"-style units ensures that no part of the rod which travels into the crankcase enters the cylinder.

The distance pieces may be vented or purged with an inert gas. The orientation of the packing varies with the application. See Sec. 2.10 and Appendix F for more details.

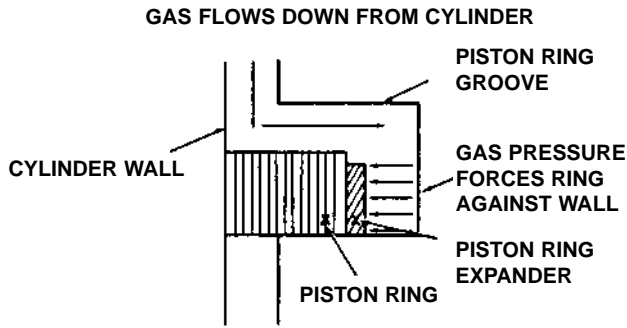

FIGURE 1.4A

### 1.4 PISTON/PISTON RINGS

Corken compressors use iron pistons that are locked to the piston rod. The standard piston ring material is a glass-filled PTFE polymer specially formulated for non-lubricated service. Piston ring expanders are placed behind the rings to ensure that piston rings seal tightly against the cylinder wall (see Figure 1.4A).

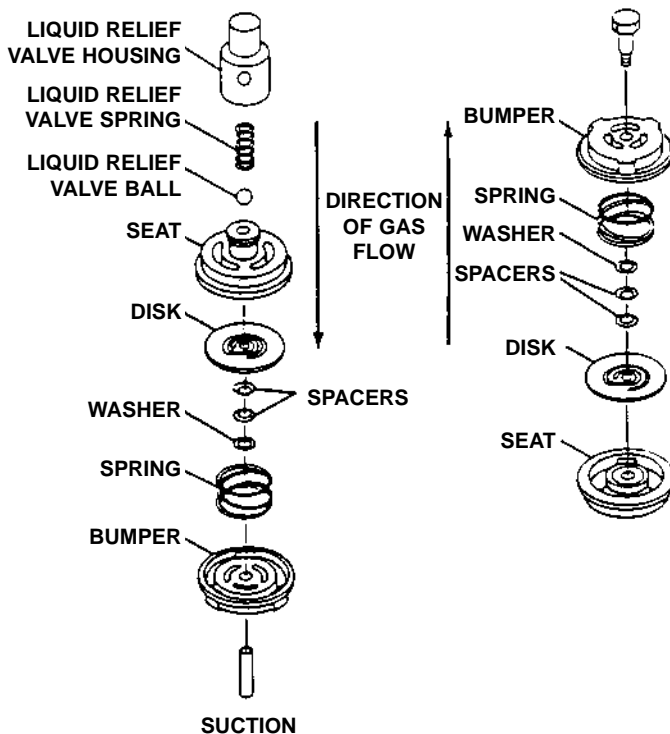

FIGURE 1.5A

CORKEN SUCTION AND DISCHARGE VALVES FOR SIZE 391 AND 491 COMPRESSORS

### 1.5 VALVES

The typical Corken compressor valve consists of a seat, bumper, spring and valve disk, as shown in Figure 1.5A. Special heat-treated alloys prolong the life of the valve in punishing, non-lubricated services. The valve opens whenever the pressure on the seat side exceeds the pressure on the spring side. The discharge valve is an inverted version of the suction valve.

### 1.6 COOLING

Most Corken compressor models are air-cooled. Water-cooled heads and cylinders are available for some applications requiring additional cooling. Two-stage compressors may be supplied with either air-cooled or water-cooled intercoolers. See Sec. 2.7 for more information about water-cooled units.

### 1.7 SUCTION VALVE UNLOADERS (OPTIONAL)

Some Corken compressors are equipped with suction valve unloaders. Check your model number against Appendix A to determine the valve/unloader arrangement for your machine. If the valve/unloader number for your machine is 3 or 4, proceed to section 1.8 (your machine has no unloaders).

The suction valve unloader is a small piston and cylinder assembly installed over the suction valve (see Figure 1.1A). The small piston is connected to a rod that extends into the suction valve assembly. The unloader piston is depressed when gas pressurized to 40 psi or more above suction pressure is injected into the unloader cylinder.

In the depressed position, the piston pushes the rod against the suction valve disk to hold the suction valve in an open position. In this position, no compression will occur, even though the pistons are still moving up and down.

The unloaders are controlled by devices which control the flow of gas into and out of the unloader cylinder. The different types of unloader controls may be summarized as follows:

**LOADLESS STARTING FOR AIR  
OR NON-CONTAMINATING OR NON-HAZARDOUS GAS**

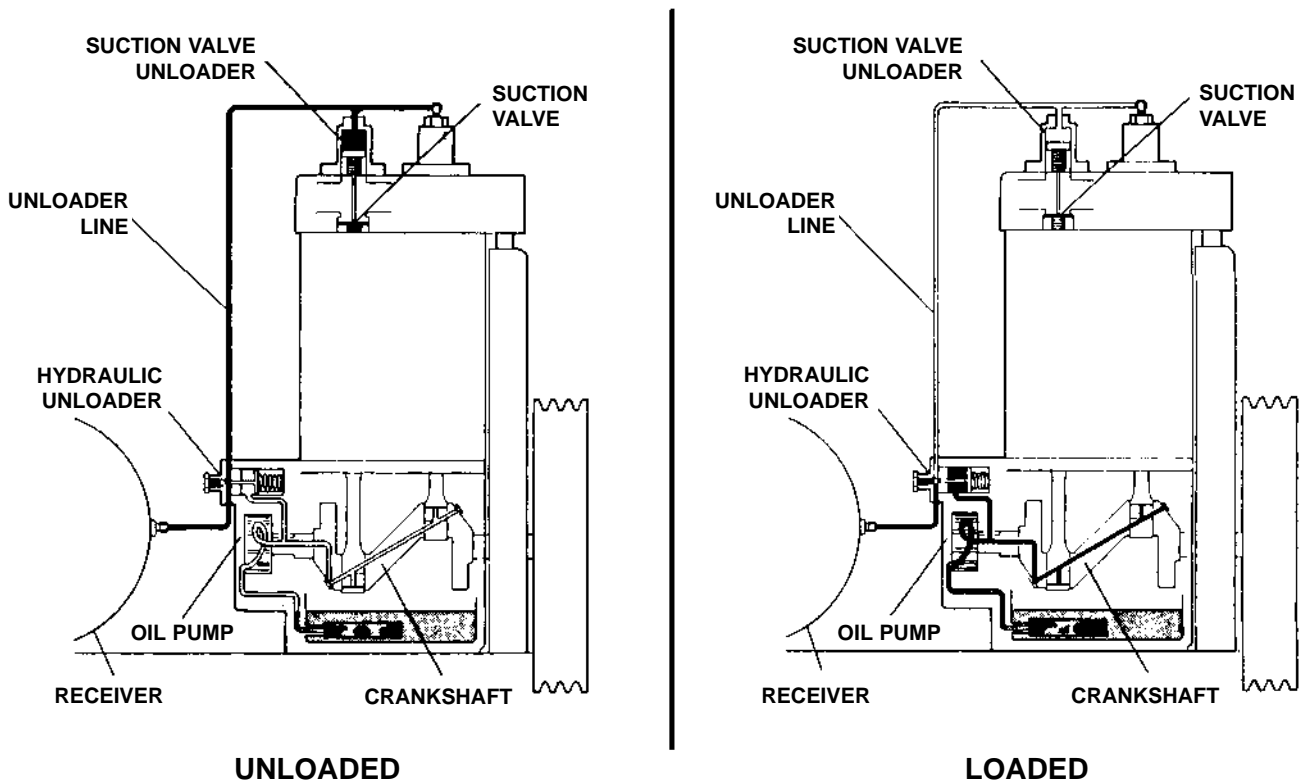

**SPECIFICATION 7  
FIGURE 1.7A**

SPECIFICATION 7 - Use only for air or non-contaminating, non-hazardous gases. The Specification 7 unloader system allows the compressor to start under no load (see Figure 1.7A). When the compressor is not running, the suction valves are held open by the pressure in the unloader line from the receiver. As the compressor starts

running, the crankcase oil pressure rises and closes the hydraulic unloader; this vents the unloader line and the suction valves may begin normal operation.

When the compressor stops, the hydraulic unloader opens again, unloading the suction valves.

**CONSTANT SPEED UNLOADING FOR AIR  
OR NON-CONTAMINATING OR NON-HAZARDOUS GAS**

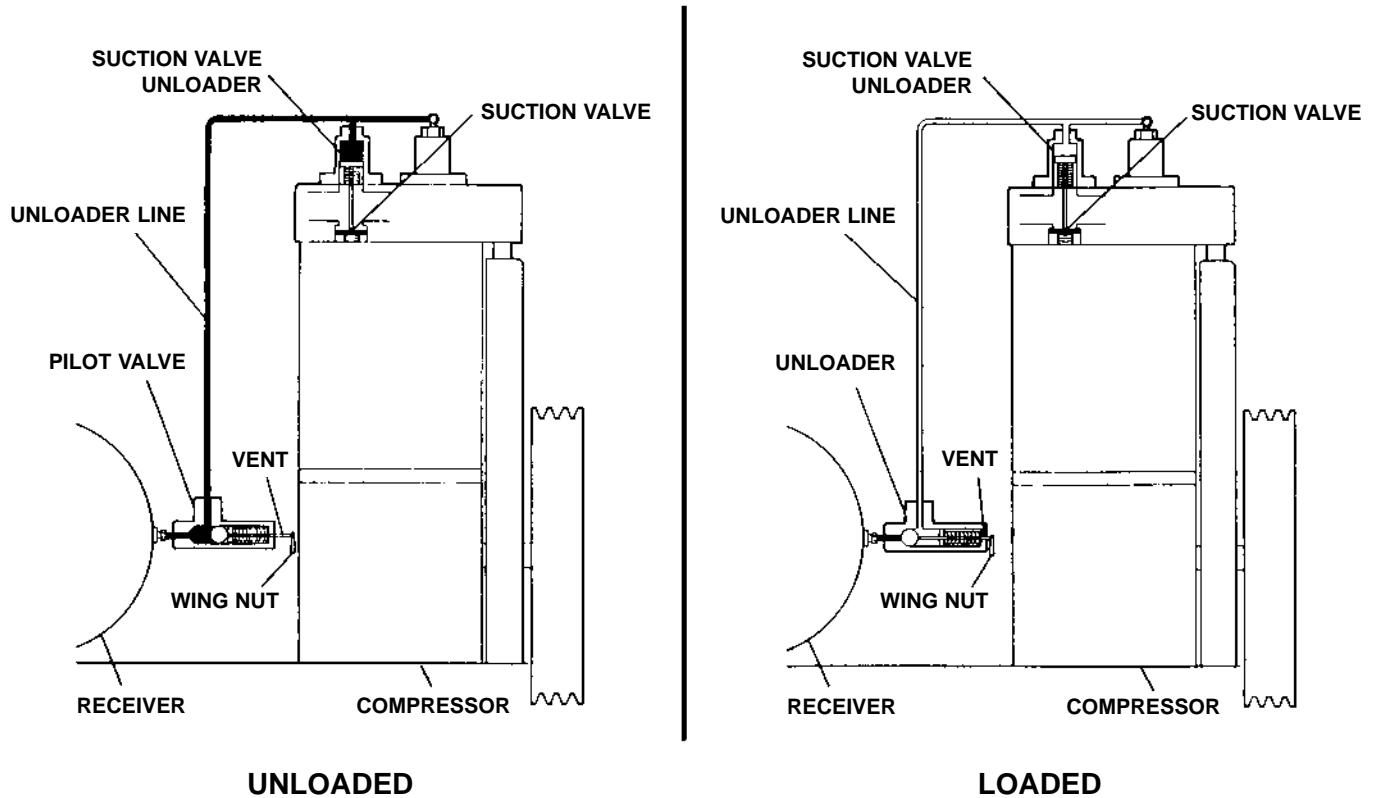

**SPECIFICATION 8  
FIGURE 1.7B**

**SPECIFICATION 8 - Use only for air or non-contaminating, non-hazardous gases.** The discharge pressure range is set by adjusting the unloader pilot valve (see Figure 1.7B). When the compressor is running and the pressure reaches the maximum setting, the unloader pilot valve opens, the line to the suction valve unloader is pressurized, and the suction valves are held open. The compressor is not running "unloaded." As the pressure in the receiver drops to the preset minimum, the pilot valve closes, the line to the suction valve unloader is vented, and the suction valves return to normal operation. See Sec. 3.4 for adjustment information.

**SPECIFICATION 7-8 -** The advantages of Specification 7 and Specification 8 unloading systems may be combined, as shown in Figure 1.7C. A control valve allows the pilot valve to be isolated from the system when start/stop control with a pressure switch is preferred. See Sec. 3.4 for adjustment information.

**DUAL CONTROL UNLOADING FOR  
AIR NON-CONTAMINATING  
OR NON-HAZARDOUS GAS**

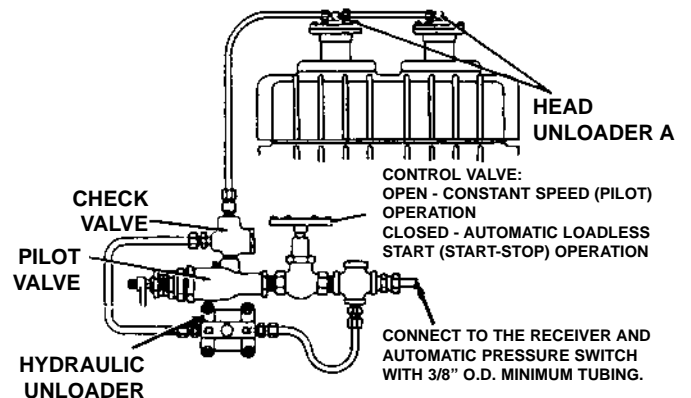

**SPECIFICATION 7 - 8  
FIGURE 1.7C**

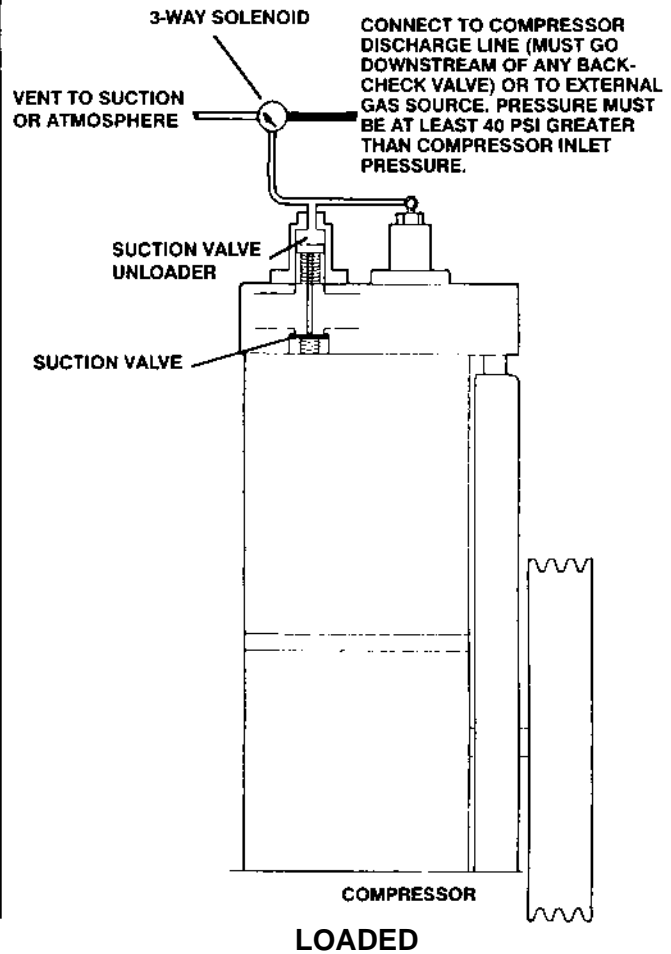
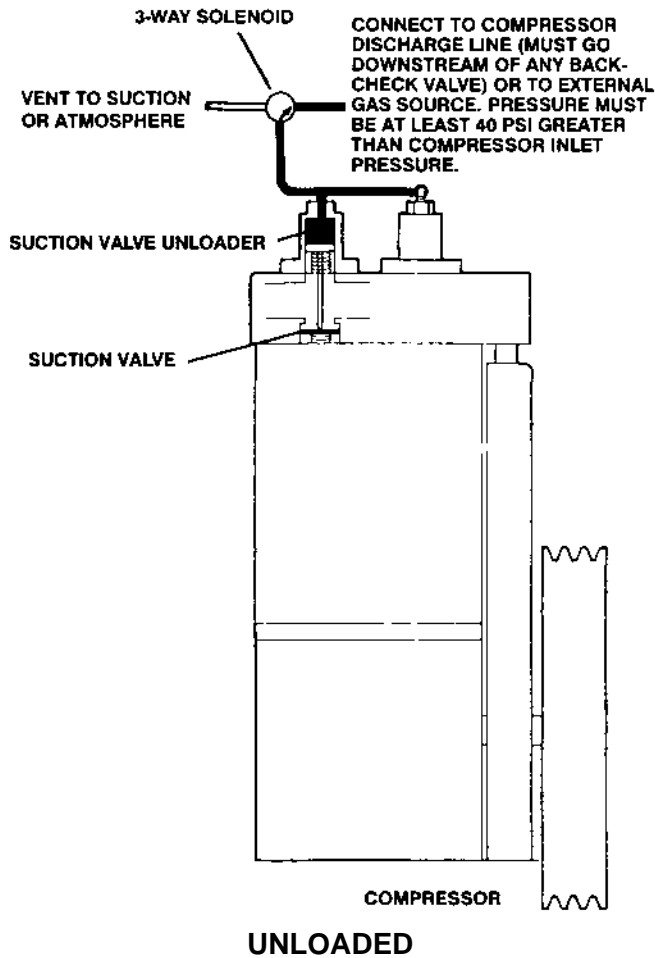

**SPECIFICATION 9  
FIGURE 1.7D**

SPECIFICATION 9 - When the gas being compressed cannot be vented to the atmosphere, electronic controls should be used as shown in Figure 1.7D. An optional three-way solenoid valve allows gas from the unloader to be vented back to the compressor suction instead of to atmosphere. A time delay may be used to achieve loadless start, a pressure switch to achieve constant-speed unloading. See Section 2.8 for typical wiring of Specification 9 unloader controls.

connected to a sheave mounted behind the flywheel (see Figure 1.8A), or by an internal sprocket and chain.

**FIGURE 1.8A**

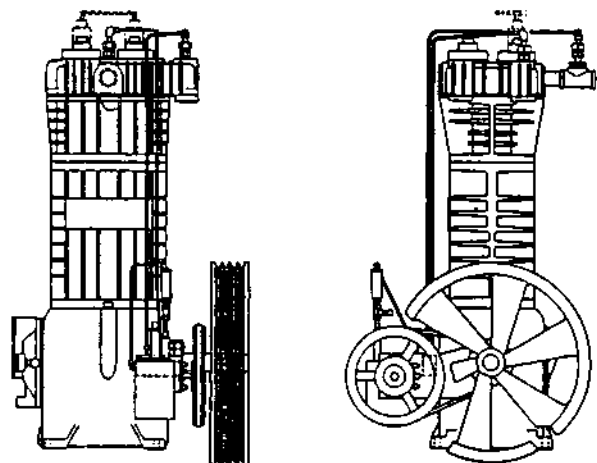

### 1.8 CYLINDER LUBRICATORS

For gas compression applications where some oil contamination is acceptable, a cylinder lubricator will typically quadruple piston ring and valve life. The cylinder lubricator is a high-pressure oil pump which injects lubricant from an external reservoir into the suction of each stage. The lubricator is mounted on the crankcase and driven by either a small V-belt

### EXTERNAL LUBRICATOR

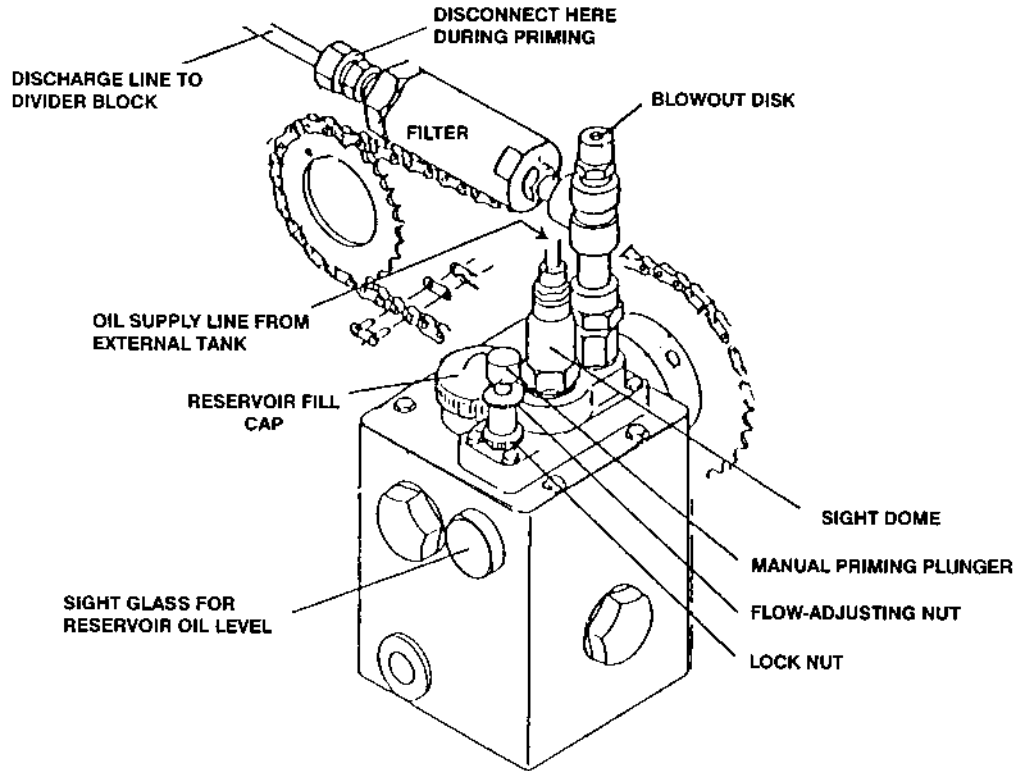

**FIGURE 1.8B**

Figure 1.8B illustrates the different parts of the lubricator. The lubricant is supplied to the lubricator pump through a 1/8" NPT connection on the plastic sight dome (Note: the Corken cylinder lubricator is not sump fed.) A blowout disk prevents the lubricator discharge pipe from being over-pressured. (See Section 2.12 for operation of the lubricator.)

Two-stage units are equipped with a filter and divider block to split the lubricant flow between the injection quills installed on each stage.

Both the compressor and the lubricator may be operated in either direction.

## CHAPTER 2

## INSTALLING YOUR CORKEN COMPRESSOR

## 2.1 LOCATION

Corken compressors are designed and manufactured for outdoor duty. For applications in which the compressor will be subjected to extreme conditions for extended periods, such as hot boiler rooms, corrosive environments, arctic or desert conditions, etc., consult Corken. Check local safety regulations and building codes to assure installation will meet local safety standards.

Corken recommends that machines compressing toxic or flammable gases be placed outdoors. If such units are placed indoors, make sure the area is well ventilated and vent the distance piece to the outdoors. Compressors with only one packing set and no distance piece are not suitable for indoor use with flammable or toxic gases.

## 2.2 FOUNDATION

Proper foundations are essential for a smooth running compression system. Corken recommends the compressor be attached to a concrete slab at least 8" thick, with a 2" skirt around the circumference of the baseplate. The baseplate should be securely anchored into the foundation by 1/2" "J" bolts, 12" long. The total mass of the foundation should be approximately twice the weight of the compressor system (compressor, baseplate, motor, etc.). After leveling and bolting down baseplate, grout the volume beneath the channel iron baseplate to prevent flexing of the top portion of the "J" bolt that extends beyond the foundation. The grout also improves the dampening capabilities of the foundation by creating a solid interface between the compressor and foundation.

On some of the longer baseplates, such as the 691-107, cut a 3-inch hole in the baseplate to fill the middle section of the channel-iron base with grout.

See additional foundation design aids in Appendix H.

## 2.3 PIPING

Proper piping design and installation is as important as the foundation to smooth operation of the compressor. Improper piping installation will result in undesirable transmission of compressor vibration to the piping.

## RECOMMENDED FOUNDATION DETAILS FOR CORKEN COMPRESSORS 91 - 691

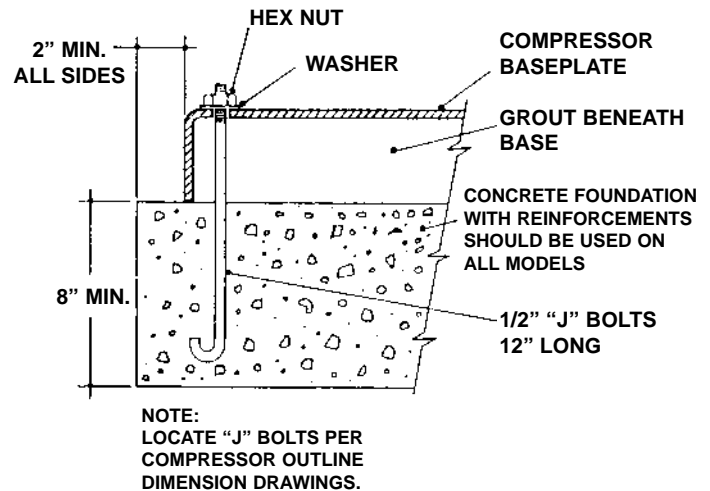

FIGURE 2.2A

**DO NOT SUPPORT PIPING WITH THE COMPRESSOR.** Unsupported piping is the most frequent cause of pipe vibration. Transmission of vibration from the compressor to the piping is minimized by using flexible connectors (see Figure 2.3A).

Pipe must be adequately sized to prevent excessive pressure drop between the suction source and the compressor, as well as between the compressor and the final discharge point. In most cases, piping should be at least the same diameter as the suction nozzle on the compressor.

If a restriction device such as a valve, pressure regulator, or back-check valve is to be installed in the compressor's suction line, the volume between the restrictive device and the compressor nozzle must be at least ten times the swept cylinder volume.

**MECHANICAL TRAP**

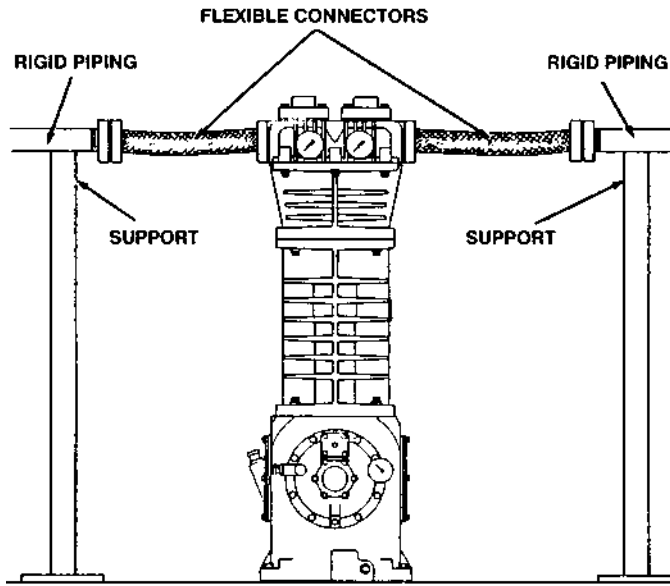

**FIGURE 2.3A**

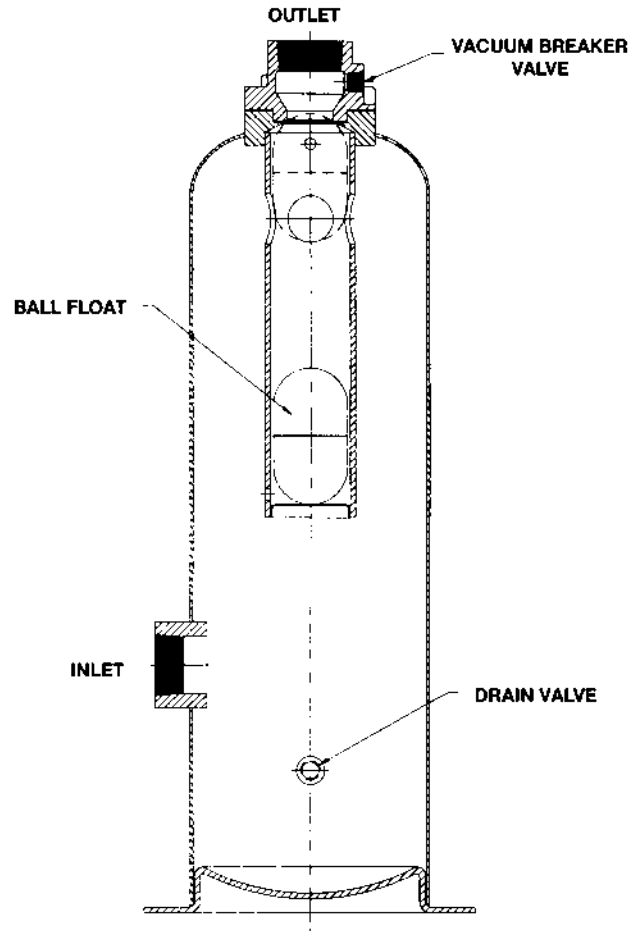

**FIGURE 2.3A**

Piping must be installed to prevent condensate from draining into the compressor. This is especially important on applications where gas is being handled at or near its saturation point.

On oil-field gas compressors, "heavy ends" such as pentane, hexane, heptane, etc., may accumulate beneath the piston over a period of time. For this reason, lubricated compressors are equipped with a drain cock to allow draining of the volume beneath the piston before start-up.

**2.4 LIQUID TRAPS**

Compressors are designed to pressurize gas, not to pump liquids. Since liquids are not compressible, the entry of even a small amount of liquid into the compressor can result in a highly undesirable phenomenon called "liquid slugging." When the compressor attempts to compress a non-compressible fluid, high-impact stresses are created that will result in serious damage to the compressor.

Where the presence of entrained liquids in the suction gas is a possibility, a liquid trap must be used to prevent the entry of liquid into the compressor.

Corken offers three types of liquid traps for removal of entrained liquids. The simplest is a mechanical float trap (see Figure 2.4A). As the liquid enters the trap, the gas velocity is greatly reduced, allowing the entrained liquid to drop out. If the liquid level rises above the inlet, the float will plug the compressor suction. The compressor creates a vacuum in the inlet piping and continues to operate until manually shut down by the operator. Before restarting the compressor, drain the trap and open the vacuum-breaker valve to allow the float to drop back to the bottom of its holder. This type of trap is only appropriate for use where the compressor is kept under fairly close observation by the operator. This trap is provided with the 109 and 107 compressor packages. (See bottom of Appendix A for details on standard Corken compressor packages.)

**AUTOMATIC LIQUID TRAP**

**ASME AUTOMATIC TRAP**

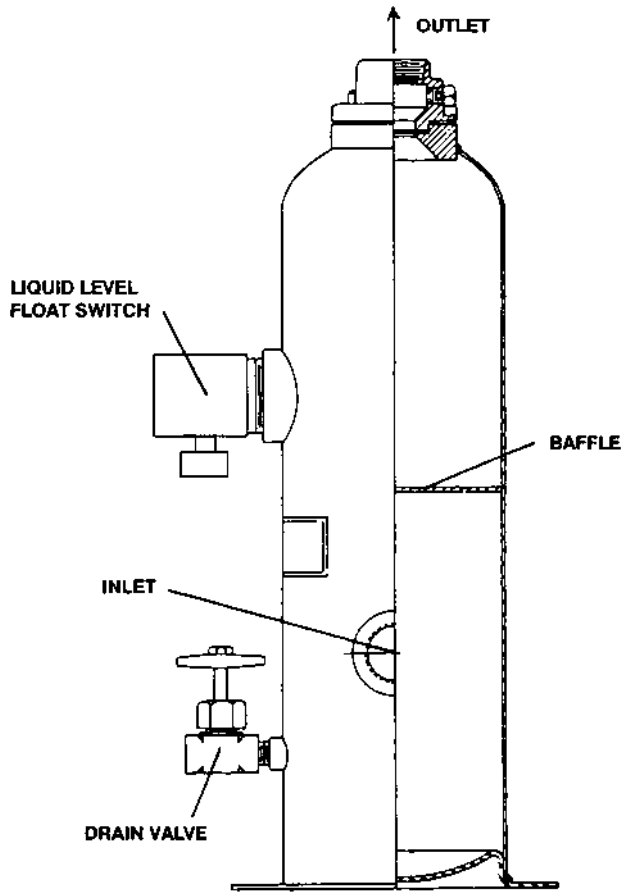

**FIGURE 2.4B**

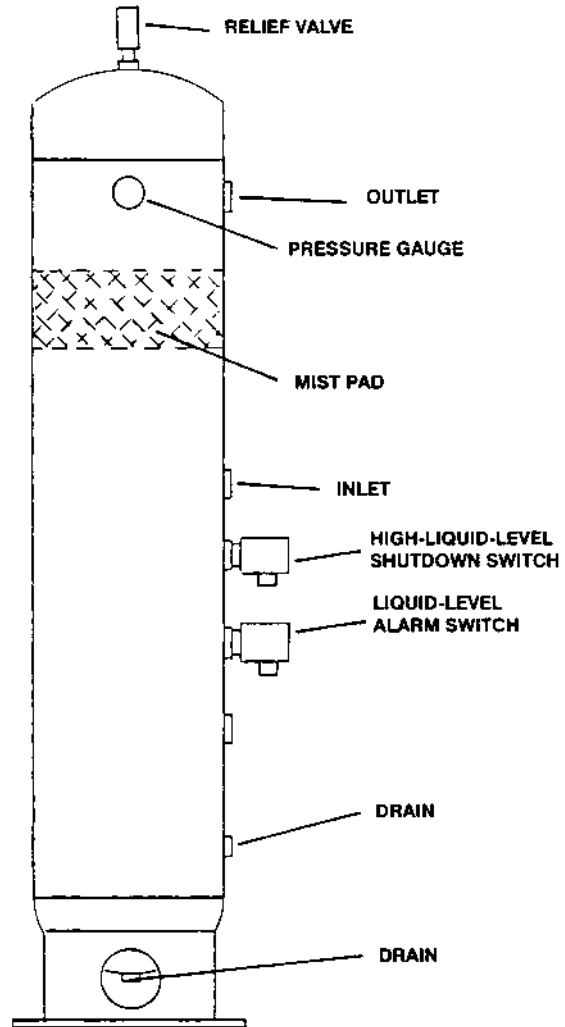

**FIGURE 2.4C**

For continuous-duty operation applications such as those found in the chemical industry, an automatic trap should be used (see Figure 2.4B). The automatic trap replaces the mechanical float with electrical float switches. If the liquid level should rise too high, the level switch will open and disconnect the power to the motor starter, stopping the compressor. This design ensures the machine will be protected even when it is not under close observation, and is standard in the -109A and -107A mounting configurations.

Corken's most sophisticated trap provides the most thorough liquid separation (see Figure 2.4C). This trap is larger and is ASME-code stamped. It contains two level switches, one for alarm and one for shutdown. In some cases, the alarm switch activates a dump valve (not included with trap) or sounds an alarm. A drain valve is included to manually drain the trap. This trap also contains a mist pad (a mesh of

interwoven wire to disentrain fine-liquid mists). The ASME-code trap is standard in the -109B and -107B mounting configurations.

A typical wiring diagram for the liquid level switch is shown in Figure 2.4D. If the switch is installed with the conduit connection in the top position, it will normally be closed, as shown in Figure 2.4D. If the conduit is in the bottom position, the switch will normally be open.

**NOTE: The level switch *MUST* be removed from the trap before grounding any welding devices to the trap or associated piping! Failure to do so will damage the switch contacts.**

**WIRING DIAGRAM**

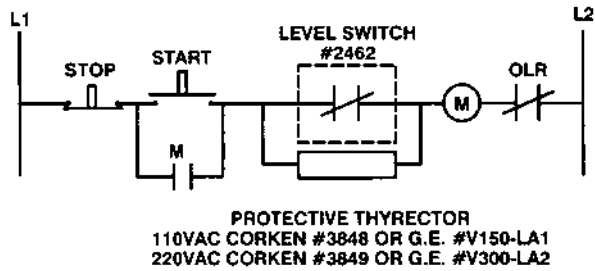

**FIGURE 2.4D**

If your compressor is equipped with a liquid trap of other than Corken manufacture make sure it is of a size adequate to thoroughly remove any liquid entrained in the suction stream.

**2.5 DRIVER INSTALLATION / FLYWHEELS**

Corken vertical compressors may be driven either by electric motors or combustion engine (gasoline, diesel, natural gas, etc.). Corken compressors are usually V-belt driven, but they are suitable for direct-drive applications as well. Direct-drive applications require an extended crankshaft to allow the attachment of a rigid metal coupling. **NOTE: FLEXIBLE COUPLINGS ARE NOT SUITABLE FOR RECIPROCATING COMPRESSORS. NEVER OPERATE A RECIPROCATING COMPRESSOR WITHOUT A FLYWHEEL.**

Select drivers so that the compressor operates between 350 to 825 RPM. Do not operate the unit without the flywheel; severe torsional imbalances will result that could cause vibration and high horsepower requirement. The flywheel should never be replaced by another pulley unless it has a higher  $wk_2$  value than the flywheel.

A humid climate can cause problems, particularly in explosion-proof motors. The normal breathing of the motor, as well as alternating between being warm when running and cool when stopped, can draw moist air into the motor. This moist air will condense, and may eventually add enough water inside the motor to cause it to fail. To prevent this, make a practice of running the motor at least once a week on a bright, dry day for an hour or so without the V-belts. In this period of time, the motor will heat up and vaporize the condensed moisture, driving it from the motor. No motor manufacturer will guarantee explosion-proof or totally enclosed (TEFC) motors against damage from moisture.

For installation with engine drivers, thoroughly review instructions from the engine manufacturer to assure the unit is properly installed.

**2.6 CRANKCASE LUBRICATION**

Non-detergent oil is recommended for Corken compressors. Detergent oils tend to keep wear particles and debris suspended in the oil, whereas non-detergent oils let them settle to the bottom of the crankcase. When non-detergent oils are not available, detergent oils usually may be substituted successfully, although compressors handling ammonia, amine, or imine gases are notable exceptions. These gases react with the detergent and cause the crankcase oil to become corrosive and contaminated. Figures 2.6A & B show recommended oil viscosities and crankcase capacities.

ACCEPTABLE CRANKCASE OIL PRODUCTS FOR CORKEN COMPRESSORS				
CONSTANT WEIGHT - NON-DETERGENT - R&O INHIBITED				
OIL PRODUCT	ISO	VI	SAE	AMBIENT TEMP
<b>Exxon®</b>				
TERESSTIC	100	95	30	65° - 100° F
	68	95	20+	45° - 70° F
	46	95	20	35° - 50° F
<b>Mobil®</b>				
RARUS 427 Reciprocating Compressor Oil	100	95	30	65° - 100° F
DTE Oil Heavy Medium	64	95	20+	45° - 100° F
Dectol R&O Oil	44	95	20	35° - 50° F
<b>Conoco®</b>				
Dectol R&O Oil	100	98	30	35° - 50° F
	68	97	20+	45° - 70° F
	46	99	20	35° - 50° F
<b>Texaco®</b>				
Regal R&O Oil	100	92	30	65° - 100° F
	68	97	20+	45° - 70° F
	46	102	20	35° - 50° F
<b>Sun®</b>				
SunVis 900 Oil	100	100	30	65° - 100° F
	68	100	20+	45° - 70° F
	46	100	20	35° - 50° F

**FIGURE 2.6A**

Compressor Model (Includes Standard, D & T Styles)	Approximate Quarts	Capacity Liters
91	0.9	0.8
290, 291, 191	1.5	1.4
390, W391, 490, 490-3, 491	3.0	2.8
590, 690, 690-4, 691	7.0	6.6

**FIGURE 2.6B**

New or rebuilt units should be filled with oil through the opening behind the compressor nameplate. This provides excellent lubrication for the crossheads on initial startup (see Figure 5.5A).

Synthetic lubricants are generally not necessary. Please consult the factory if you are considering the use of a synthetic oil.

### 2.7 COOLING WATER

Certain Corken compressor models may be equipped with water-cooling features where air cooling is not sufficient. Appendix A summarizes water-cooling options available on Corken compressors.

Although the top packing set of the 590, 690, 690-4 and 691 (Standard and "D" style) may be water cooled, these units are designed to run completely air cooled, so water cooling the packing is not required.

Usually a two-way solenoid valve is used to shut off cooling-water flow when the compressor is not operating (see Section 2.8 for typical wiring).

Increasing cooling-water flow rates will improve cooling up to a certain point. For most watercooled Corken compressors, flow rates of 1 to 2 GPM are most practical, but you may increase the flow rate if it significantly improves cooling. The best water flow rate and path will vary from application to application.

Normally, the water discharge temperature should be 120-130°F (49-54°C) to ensure optimum ring and valve life. Lower water temperatures may be used **only** if the gas has no condensables.

### 2.8 WIRING

Wiring of electric motor drivers and compressor controls and instrumentation should only be done by trained electricians.

Figure 2.8A shows a general wiring schematic for typical shutdown and control devices such as low oil-pressure switches, pressure switches, high temperature switches, water-control solenoid, etc. The wiring diagram also shows how to wire 3-way solenoid-valve controls on compressors with Spec. 9 unloader systems.

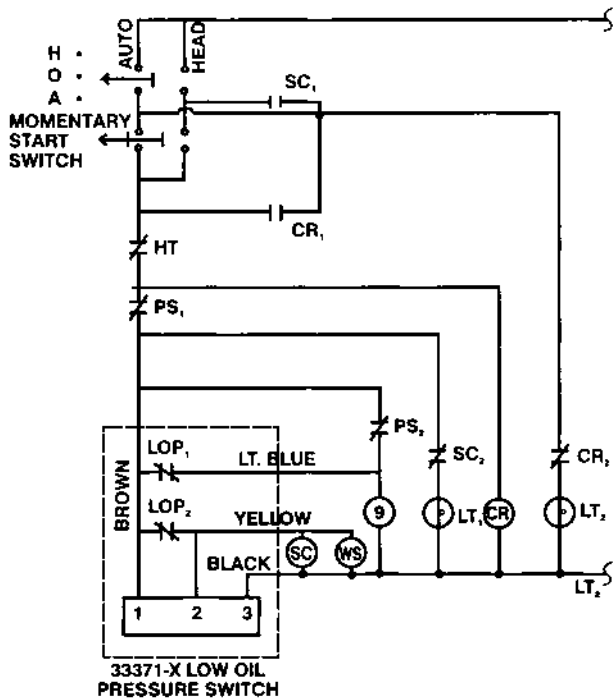

- SC Starter coil and two contacts - SC<sub>1</sub> and SC<sub>2</sub>.
- CR Control relay and two contacts - CR<sub>1</sub> and CR<sub>2</sub>.
- HT High-temperature switch. Additional two-line devices may be placed in series with HT. These devices cause complete shutdown with no automatic restart.
- PS<sub>1</sub> Pressure switch. Additional two-line control devices may be placed in series with PS<sub>1</sub>. These devices can both stop and start the unit. A pressure switch for start-stop control would be placed here.
- PS<sub>2</sub> Pressure switch to affect constant-speed unloading via the #9 three-way solenoid valve and the Spec. 9 suction-valve unloaders.
- 9 Other two-line control devices can be placed in series with PS<sub>2</sub>. (Example: Machine is required to unload on either low-inlet pressure or high-discharge pressure.)
- Three-way solenoid valve used to control suction-valve unloaders. When energized, unit is unloaded.
- 3371-X Corken low-oil-pressure switch with built-in 30 second time delay. NEMA 7 - U.L. listed.
- LOP, LOP<sub>1</sub> Low-oil-pressure switch in 3371-X.
- WS Two-way solenoid to control coolant flow to compressor and/or heat exchange.
- LT<sub>1</sub> Low-oil-pressure indicator lamp. (Controlled via LOP.)
- LT<sub>2</sub> High-temperature indicator lamp. (Controlled via HT.)

#### Circuit Functions

1. Allows start-stop control with loadless starting.
2. Allows constant-speed unloading.
3. Provides shutdown for high-discharge temperature, high-discharge pressure (or low-suction pressure), and low oil pressure and indication of cause of shutdown. Other shutdown controls may be easily added.

FIGURE 2.8A

A 10 to 30 second time delay is required to activate a 3-way solenoid valve during startup to affect loadless starting. Corken's 3371-X low-oil pressure switch is equipped with a time delay that may be used for this purpose. If a different brand of LOP switch is used which does not have a time delay, a time delay can be added to the control panel.

To activate the solenoid when discharge pressure exceeds a certain point (constant-speed unloading), a pressure switch should be wired into the system as shown in Figure 2.8A (the pressure switch is designated PS<sub>2</sub> in the schematic). For more on Spec 9 unloading systems, see Section 1.7.

## 2.9 SHUTDOWN/ALARM DEVICES

For many applications shutdown/alarm switches will provide worthwhile protection that may prevent serious damage to your compressor system. All electronic devices should meet local code requirements. Shutdown/alarm devices typically used on Corken compressors are:

**Low-Oil-Pressure Switch** - shuts down the unit if crankcase oil pressure falls below 12 psi due to oil pump failure or low oil level in crankcase.

**High-Temperature Switch** - shuts down unit if the normal discharge temperature is exceeded. Strongly recommended for all applications. Typically the set point is about 30°F (17°C) above the normal discharge temperature.

**Low-Suction, High-Discharge Pressure** - shuts down unit if inlet or outlet pressures are not within preset limits.

**Vibration Switch** - shuts down unit if vibration becomes excessive. Recommended for units mounted on portable skids.

See Section 2.8 for typical wiring instructions.

## 2.10 PURGING AND DRAINING OF DISTANCE PIECES "D"- AND "T" STYLE COMPRESSORS ONLY.

The key to leakage control and oil-free operation of Corken compressors is the distance piece. Distance pieces are equipped with tapped holes to purge vent and drain (see Figure 2.10A). Proper connections to and from these tapped holes are essential for optimum compressor performance.

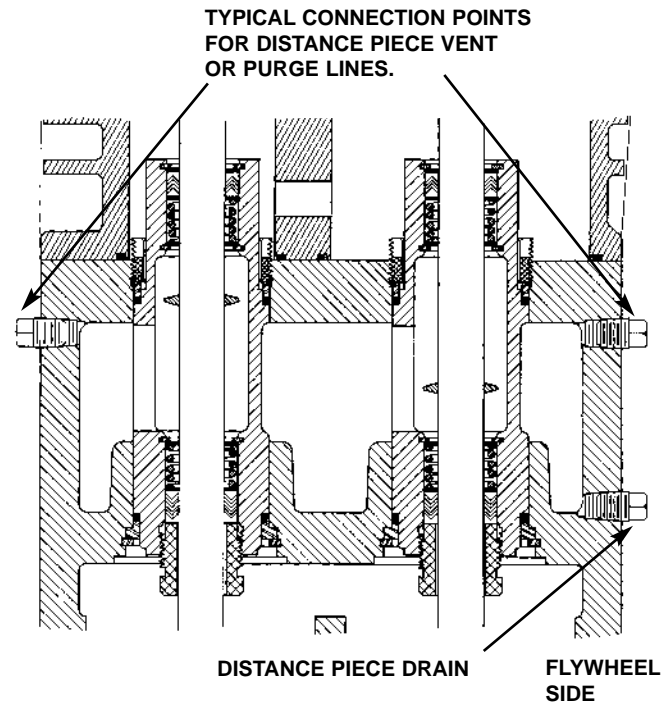

FIGURE 2.10A

*Since some oil will pass the bottom packing set, regular draining of the distance piece is essential to maintain oil-free operation (See Figure 2.10A).* Corken recommends draining the distance piece once a week for units in continuous-duty operation. Installing a drain cock to the distance piece drain will help simplify draining of the distance piece.

Compressors with Style "B" or "E" packing arrangements (see Appendix A and F) will have the vent connection tubed to the discharge of the compressor's first stage (Style B) or second stage (Style E). Compressors with "A"-Style packing arrangements are shipped with all connections plugged. Compressors with "D"-Style packing arrangements have large openings in the distance piece so the unit's distance piece is continuously vented and drained (used on oxygen applications only).

Corrosive gases should be prevented from entering the crankcase, since even minute amounts of leakage into the crankcase can seriously contaminate the crankcase oil. To prevent this contamination, the distance piece may be purged, buffered, or both purged and buffered by a dry, clean, non-corrosive gas like air or nitrogen.

**PURGING.** Purging without buffering can only be performed on units with "A"-Style packing arrangements. Purge gas at a pressure fewer than the suction pressure fed into the distance piece through the purge connection and discharged from the vent. Moisture and condensate can be removed from the distance piece with the purge gas by placing the vent connection at the bottom of the distance piece. Leakage into the distance piece is quickly diluted by the purge gas and swept away. The purge gas should be vented to a safe release area, flare, or treatment facility, depending on the gas and on local regulations.

**PURGE & BUFFER.** For applications with vacuum inlet pressures and/or low operating pressure (200 psig or less), buffering offers advantages over purge-only systems. For buffered systems, the distance piece is pressurized ABOVE discharge pressure with a clean, dry, inert gas (usually dry air or nitrogen). The top packing set is inverted to point up. For "B"- & "E"-Style packing arrangements, disconnect and plug lines running to the discharge of the compressor (first or second stage). Otherwise, the purge gas will tend to leak into the compression chamber. Purging and buffering can be accomplished by venting the distance piece to a safe release area. A backpressure valve may be used to maintain proper distance piece pressure.

**VENT.** Only compressors used for flammable but non-toxic, non-corrosive gases or for indoor applications, require the distance piece to be vented to an appropriate release area, flare, or treatment facility.

**DOUBLE-DISTANCE-PIECE COMPRESSORS.** For highly corrosive gases such as chlorine, VCM, hydrogen sulfide, etc., Corken recommends the use of a double-distance-piece compressor. Where purge gas is not available, use the "G"-Style packing arrangement (see Appendix F). If purge gas is available, use the "H"-Style arrangement.

For some applications, purging systems other than the typical ones recommended here might be utilized. If you design a special purge system for your compressor, remember that the higher pressure and the packing spring must be on the open end of the V to ensure good sealing.

**HIGHLY CORROSIVE GASES.** The compressor should be blocked from the system via valves on the suction and discharge piping, then purged with dry inert gas before being shut down. Experience has proven this significantly lowers corrosion damage to the machine.

## 2.11 RELIEF VALVES

Any line leading to or from the compressor that can be blocked by a valve or other restrictive device **must** be equipped with a relief valve. The relief valve should be able to relieve a volume of gas higher than the piston displacement of the compressor. Relief valves should be made of materials compatible with the gas being compressed. For compressors handling toxic or flammable gases, the relief valves should be piped to an area where it is safe to release gas.

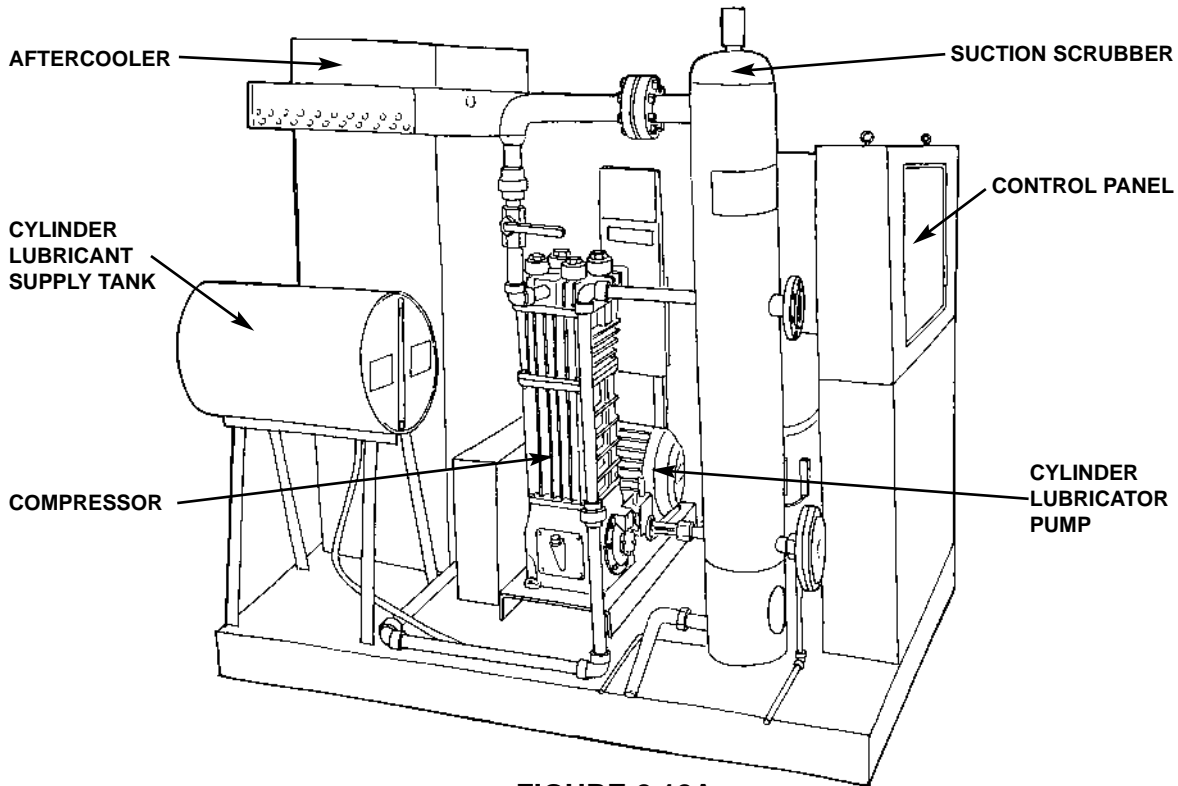

FIGURE 2.12A

## 2.12 CYLINDER LUBRICATOR

(Lubricated Models Only)

The lubricator on lubricated Corken compressors must be supplied with oil from an external supply tank, NOT from the compressor crankcase or lubricator sump. Typically, a 5- to 10-gallon tank mounted above the lubricator as shown in Figure 2.2A works well.

The best type of lubricant will vary from application to application, depending on the gas and the compressor discharge temperature. Corken recommends that users consult a reputable supplier of industrial lubricants for selection of the cylinder lubricant.

Before starting up the compressor, the cylinder lubrication system must be primed to prevent the system from "air locking." Procedures for priming the lubricator:

1. Check that all tubing is free of kinks. Replacement tubing should be clean and the ends free of burrs.
2. Fill reservoir with oil.

3. If oil is visible in sight dome, go to Step 7.
4. Remove sight dome.
5. Fill pump.
6. Replace sight dome (finger-tight only).
7. Connect tubing between top of sight dome and external supply tank.
8. Remove discharge tubing from filter.
9. Prime by manually pumping plunger in front of sight dome until air bubbles are purged and oil is clear.
10. Reconnect discharge tubing to filter.
11. Operate compressor manually to check stroke, alignment and operation.
12. Precautions taken at this time will eliminate the possibility of malfunction and prevent damage to your lubricator or equipment.

## FLOW ADJUSTMENT

The lubricator may be adjusted to provide a delivery of 0 to 3.4 drops per stroke of the lubricator plunger. The lubrication rate may be approximated as follows:

Sizes 190 to 491 Compressor RPM X .0063 X  
Delivery per stroke

Sizes 590 to 691 Compressor RPM X .0151 X  
Delivery per stroke

One Drop = 0.0024 cubic inches.

Ideal lubrication rates depend on the application. As long as the proper cylinder lubricant is chosen, over-lubrication usually is not a problem.

To adjust the flow rate, loosen the lock nut on the manual-priming plunger stem. Turn the flow adjusting nut counterclockwise (up) to increase the flow rate and clockwise (down) to decrease the flow rate. Retighten the lock nut after adjusting the flow. To ensure best lubricator performance:

1. Use only clean oil.
2. Keep lubricator reservoir full of oil.
3. Make sure connections stay tight.
4. Make sure oil tubing is firmly supported to prevent vibration.
5. Make sure lubricator-drive-system components stay aligned.
6. Make sure all mounting bolts stay tight.

## NO-FLOW SHUTDOWNS

On unattended compressor installations it is good practice to install a no-flow shutdown switch to stop the compressor if the cylinder lubrication system fails. NOTE: No-flow switches need a 3- to 4-drops-per-minute flow rate to indicate a "flowing condition."

## EXTERNAL LUBRICATOR

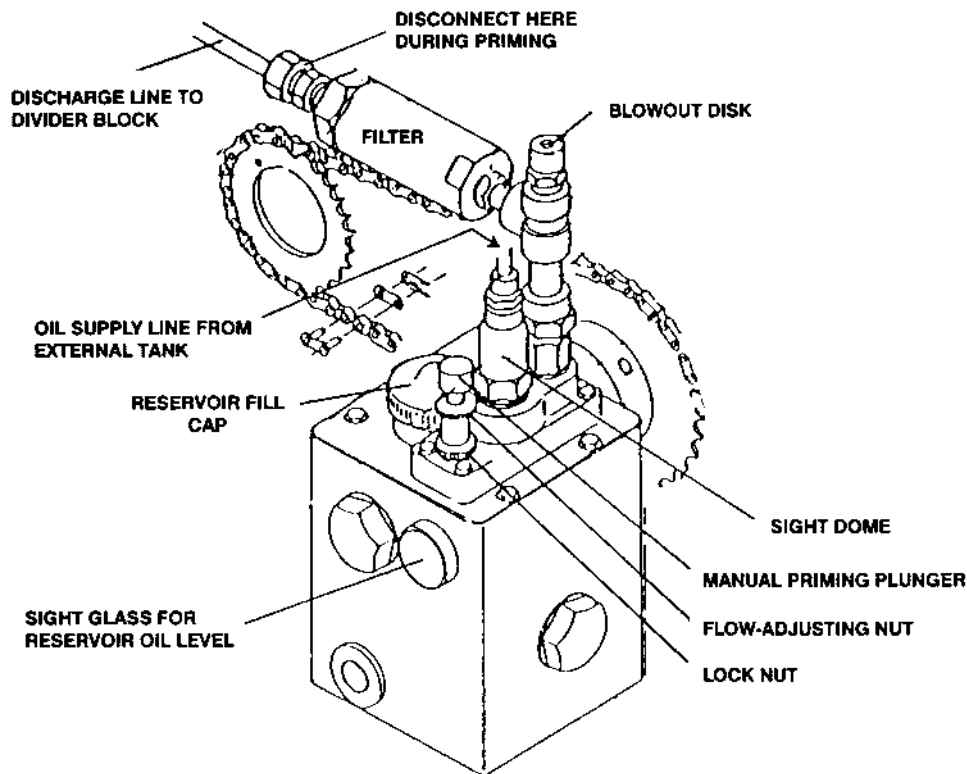

FIGURE 2.12B

CHAPTER 3

STARTING UP YOUR CORKEN COMPRESSOR

(NOTE: READ ENTIRE CHAPTER BEFORE GOING TO START-UP CHECKLIST.)

3.1 INSPECTION AFTER EXTENDED STORAGE

If your compressor has been out of service for a long time, verify that the cylinder bore and valve areas are free of rust and other debris (see the maintenance section of this manual for valve and/or cylinder head removal instructions).

Drain the oil from the crankcase and remove the nameplate and crankcase inspection plate. Inspect the running gear for signs of rust and clean or replace parts as necessary. Replace the crankcase inspection plate and fill the crankcase with the appropriate lubricant. Squirt oil on the cross-heads and rotate the crank by hand to ensure that all bearing surfaces are coated with oil.

Rotate the unit manually to ensure that the running gear functions properly. Replace the nameplate and proceed with start-up.

3.2 FLYWHEEL AND V-BELT ALIGNMENT

**Before working on the drive assembly, be sure that the electric power is disconnected.** When mounting new belts, always make sure the driver and compressor are close enough together to avoid forcing.

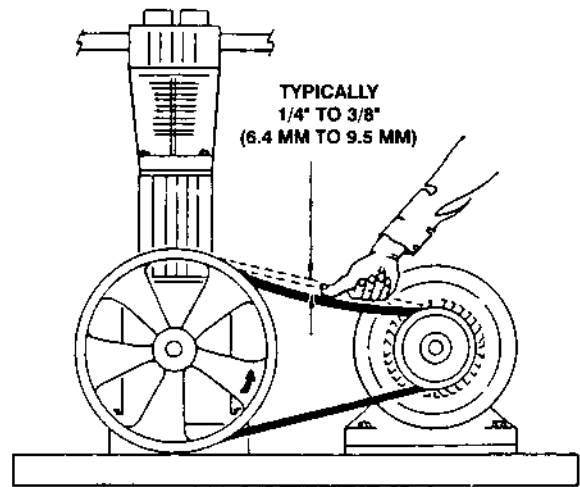

FIGURE 3.2B

Normal rotation is counterclockwise, facing the flywheel. This is important for two-stage units with intercoolers.

Improper belt tension and sheave alignment can cause vibrations, excessive belt wear and premature bearing failures. Before operating your compressor, check the alignment of the V-grooves of the compressor and drive sheaves: visual inspection with often indicate if the belts are properly aligned, but use of a square is the best method.

The flywheel is mounted on the shaft via a split, tapered bushing and three bolts. These bolts should be tightened in an even and progressive manner until torqued as specified below. There must be a gap between the bushing flange and the sheave when installation is complete. **Always check the flywheel runout before start-up and readjust if it exceeds the value listed in Appendix E.**

FLYWHEEL INSTALLATION

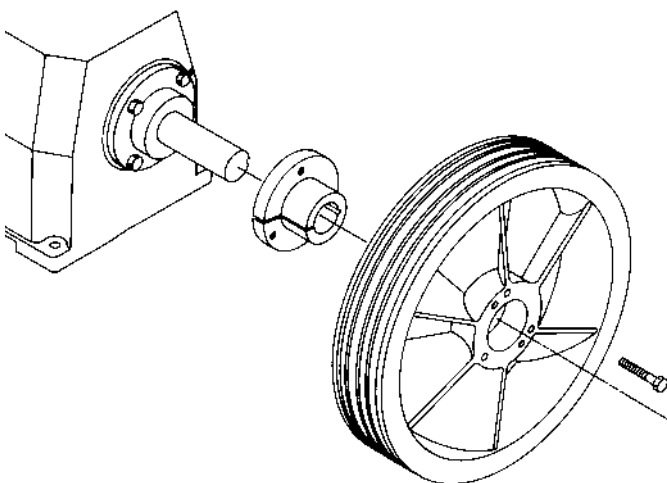

FIGURE 3.2A

Bushing Size	Diameter In.	(cm)	Bolt Torque ft.-lb. (kg-meter)
SF	4.625	(11.7)	30 (4.1)
E	6.0	(15.2)	60 (8.3)
J	7.25	(18.4)	135 (18.7)

Tighten the belts so that they are taut but not extremely tight. Consult your V-belt supplier for specific tension recommendations. Belts that are too tight may cause premature bearing failure.

### 3.3 CRANKCASE OIL PRESSURE ADJUSTMENT

Corken compressor Models 190 through 691 are equipped with an automatically reversible geartype oil pump. (If your compressor is the splash lubricated Model 91, proceed to Section 3.4.) Ensure that the pumping system is primed and the oil pressure properly adjusted to assure smooth operation.

Before starting your compressor, check and fill the compressor crankcase with the proper quantity of lubricating oil.

To assure critical lubrication of crossheads and crosshead guide during the initial start-up period:

- Remove inspection plate from crosshead guide.
- Fill crankcase with lubricating oil through the inspection plate opening.
- Check crankcase oil level at the oil bayonet.
- Re-install the inspection plate and gasket.
- Follow any other pre-start-up procedures that may be necessary in your application.
- Start compressor, observing the crankcase oil pressure gauge. If oil-pressure gauge does not register 20 - 30 PSIG after 30 seconds, stop the unit. Refer to Trouble-Shooting Guide in Important Instruction Book. Consult the Factory if condition cannot be corrected.
- Double-check the crankcase oil level.

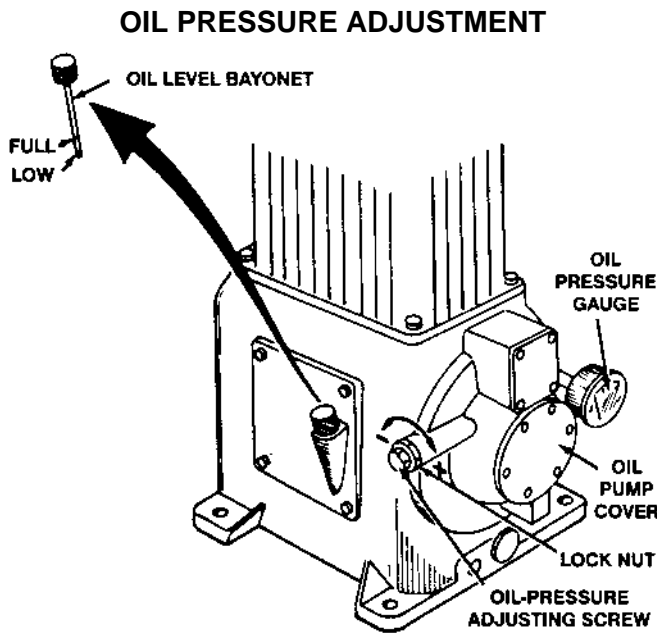

FIGURE 3.3A

### TUBING INSTALLATION FOR LOADLESS STARTING SYSTEM (SPEC 7)

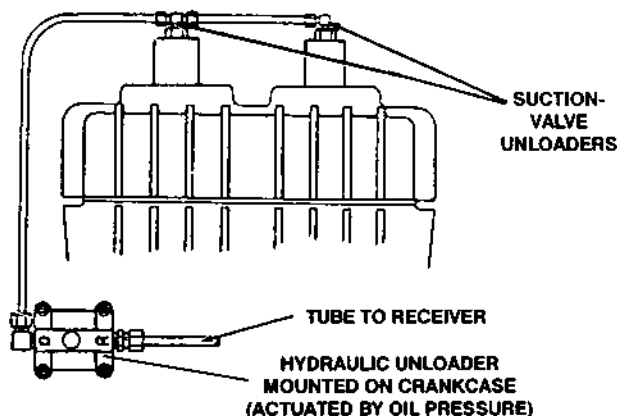

FIGURE 3.4A

When the compressor is first started, observe the crankcase oil pressure gauge. If the gauge fails to indicate pressure within 30 seconds, stop the machine. Remove the pressure gauge. Restart the compressor and run it until oil comes out of the pressure gauge opening. Re-install the gauge.

The oil pressure should be about 20 psi (2.4 Bars) minimum for normal service. If the discharge pressure is above 200 psi (14.8 Bars) or if the compressor is equipped with a hydraulic unloader (Specification 7 or 78; see Figure 3.4A), the oil pressure must be maintained at a minimum of 25 psi (2.7 Bars). The oil pressure is regulated by a spring-loaded relief valve mounted on the bearing housing opposite the flywheel. As shown in Figure 3.3A, turn the adjusting screw clockwise to increase the oil pressure, counterclockwise to lower it. Be sure to loosen the adjusting-screw lock nut before trying it after any adjustment.

### 3.4 ADJUSTMENT OF MECHANICAL UNLOADER CONTROLS

NOTE: If your compressor is not equipped with mechanical unloader control (valve / unloader Spec. 7, 78, and 9; see Appendix A to determine if this applies to your machine), proceed to Section 3.5. See Section 1.7 for explanation of how suction valve unloaders work.

**TUBING INSTALLATION FOR CONSTANT SPEED UNLOADING SYSTEM (SPEC 8)**

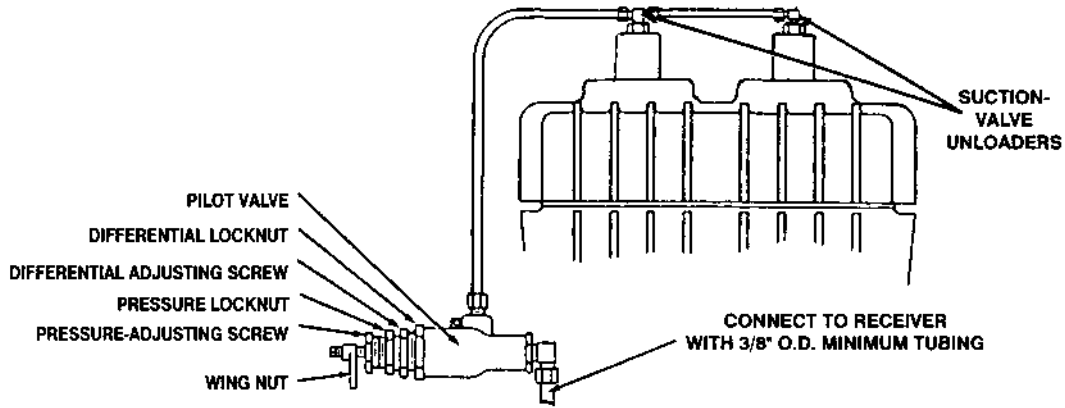

**FIGURE 3.4B**

**CONSTANT SPEED - (VALVE/UNLOADER SPEC. 8)**

The unloading pressure is adjustable and is regulated by the pressure-adjusting screw (turn clockwise to increase and counterclockwise to decrease). Tighten lock nut after adjusting.

The differential (difference between unloading and loading pressure) is modified by using the differential adjusting screw. Increase by turning clockwise, decrease by turning counterclockwise. After changing, tighten lock nut.

The pilot valve is fitted with different springs for different pressure ranges.

Red Spring	30-70 psi
Lt. Yellow Spring	71-150 psi
Lt. Green Spring	151-500 psi

**COMBINATION CONTROL - (VALVE UNLOADER SPEC. 78)**

Operation of the combination control system is maintained by the control valve shown in Figure 3.4C. When the valve is closed, the unit will operate as a loadless start unit as described above. If the valve is open, operation will be constant-speed; set the pilot valve (as described above) to a lower cut-out pressure than your pressure switch.

**TUBING INSTALLATION FOR COMBINATION CONTROL SYSTEM (SPEC 78)**

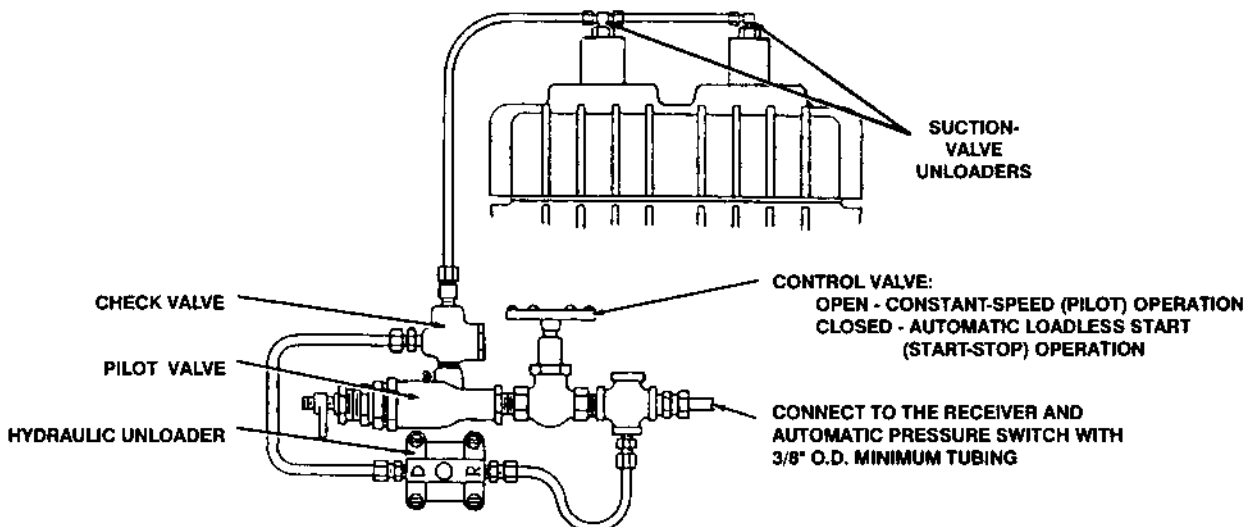

**FIGURE 3.4C**

### 3.5 STARTUP CHECK LIST

***Please verify all of the items on this list before starting your compressor! Failure to do so may result in a costly (or dangerous) mistake.***

#### BEFORE STARTING THE COMPRESSOR:

1. Become familiar with the function of all piping associated with the compressor. Know each line's use!
2. Verify that actual operating conditions will match anticipated conditions.
3. Ensure that line pressures are within cylinder-pressure ratings.
4. Clean out all piping.
5. Check that distance piece vents are tubed or plugged as desired.
6. Check all mounting shims, cylinder and piping supports to ensure that no undue twisting forces exist on the compressor.
7. Verify that strainer elements are in place and clean.
8. Verify that cylinder bore and valve areas are clean.
9. Check V-belt tension and alignment. Check drive alignment on direct-drive units.
10. Rotate unit by hand. Check flywheel for wobble or play.
11. Check crankcase oil level and all other fluid levels (lubricator, radiator, oil reservoirs, etc.).
12. Drain all liquid traps, separators, etc.
13. Verify proper electrical supply to motor and panel.
14. Check that all gauges are at zero-level reading.
15. Test piping system for leaks.
16. Purge unit with air before pressurizing with gas.

17. Carefully check for any loose connections or bolts.
18. Remove all stray objects (rags, tools, etc.) from vicinity of unit.
19. Verify that all valves are open or closed, as required.
20. Double-check all of the above.

#### AFTER STARTING THE COMPRESSOR:

1. Verify and note proper oil pressure. Shut down and correct any problem immediately.
2. Observe noise and vibration levels. Correct immediately if excessive.
3. Verify proper compressor speed.
4. Examine entire system for gas, oil or water leaks.
5. Note rotation direction.
6. Check start-up voltage drop, running amperage and voltage at motor junction box (not at the starter).
7. Verify proper lube rate (lubed units only).
8. Test each shut-down device and record set points.
9. Test all dump valves, relief valves and unloaders.
10. Check and record all temperatures, pressures and volumes after 30 minutes and 1 hour.
11. After 1 hour of running time, tighten all head bolts, valve hold-down bolts, and baseplate bolts.

CHAPTER 4

ROUTINE MAINTENANCE CHART

ITEM TO CHECK	Daily	Weekly	Monthly	Six Months	Yealy
Crankcase oil pressure	X				
Compressor discharge pressure	X				
Overall visual check	X				
Crankcase oil level			**	**	
Drain moisture from accumulation points		X			
Drain distance piece		X			
Clean cooling surfaces on compressor and intercooler		X			
Lubricator supply-tank level		X			
Check belts for correct tension			X		
Inspect and clean filter felts on control pilot (Valve Spec. 78, 8)			X		
Inspect and clean filter felts on crankcase hydraulic unloader (Valve Spec. 7, 78)			X		
Inspect valve assemblies				X	
Lubricate motor bearings in accordance with manufacturers' recommendations				X	
Inspect motor-starter contact points					X
Inspect piston rings				*	X

\* Piston ring life varies greatly, depending on application, gas, and operating pressures. Consult factory for additional recommendations for your specific applications.

\*\* Change oil and filter every 1000 hours of operation or every 3 months, whichever occurs first. If the oil is unusually dirty or contaminated by the process gas, change it as often as needed to maintain a clean oil condition.

CHAPTER 5

ROUTINE SERVICE AND REPAIR PROCEDURES

COMPRESSOR SIZES 91, 191, 291

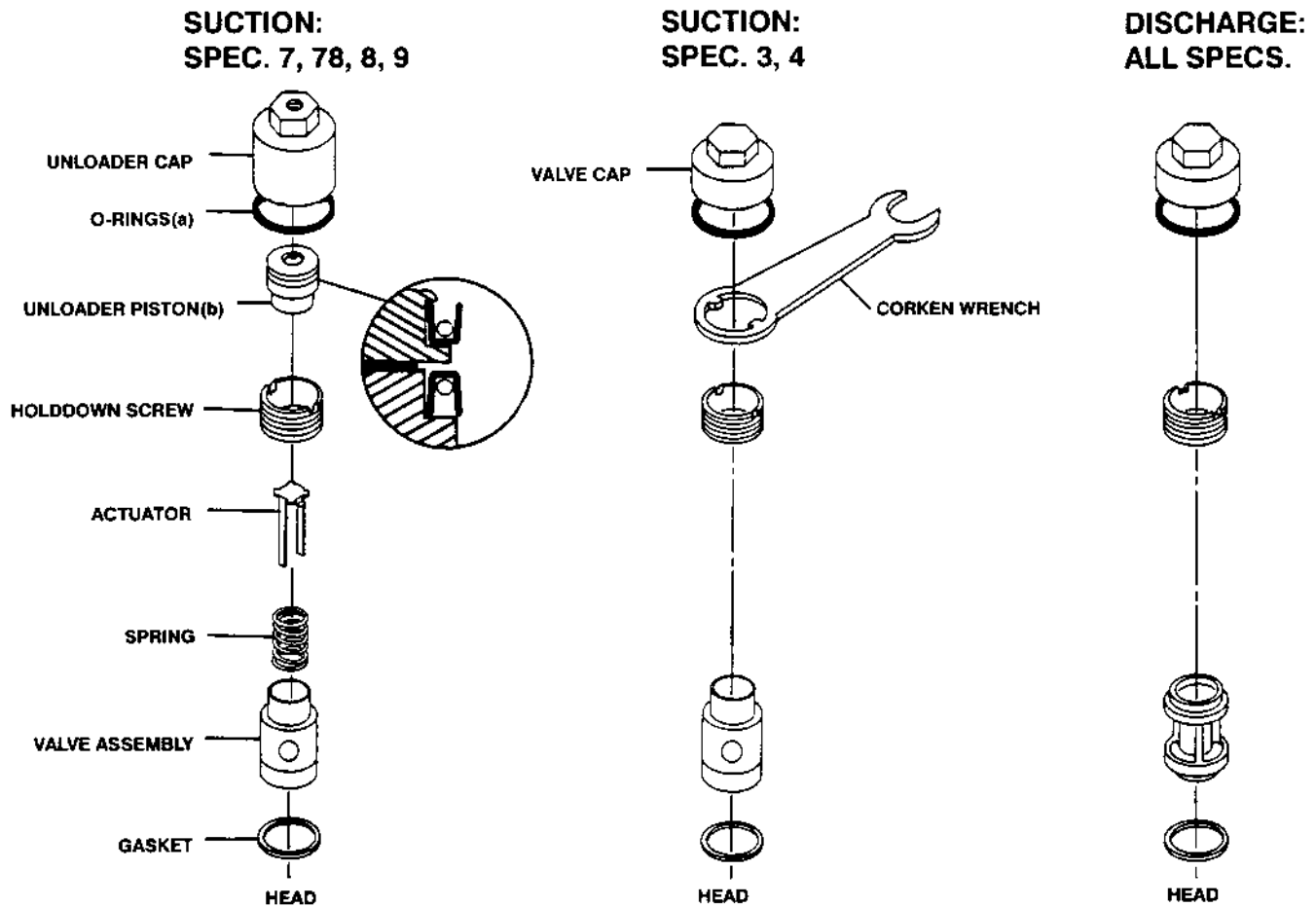

NOTES:

- (a) Older units may have a metal gasket instead of the O-Ring.
- (b) If the unloader is disassembled or new, seals are required.
  - (1) Replace the seals in proper orientation (see detail).
  - (2) Apply Loctite #290 to the screw threads when assembling the unloader piston.

FIGURE 5.1A

5.1 VALVES

**CAUTION:** Always relieve pressure in the unit before attempting any repairs.

Low capacity, overheating, noise and vibration are all indications of possible valve failure. Because valve problems can manifest themselves in so many different forms, valve inspection is frequently the best first step in troubleshooting poor performance.

To remove and inspect valves, *begin by depressurizing and purging* (if necessary) the unit. Next, remove the valve cap or unloader assembly and then remove the valve holddown screw (see Figure 5.1A through 5.1C) with the special wrench supplied with the compressor. Valves in sizes 91 through 291 may then be removed. Sizes 391 through 691 require removal of the valve cover plate before the valves can be removed.

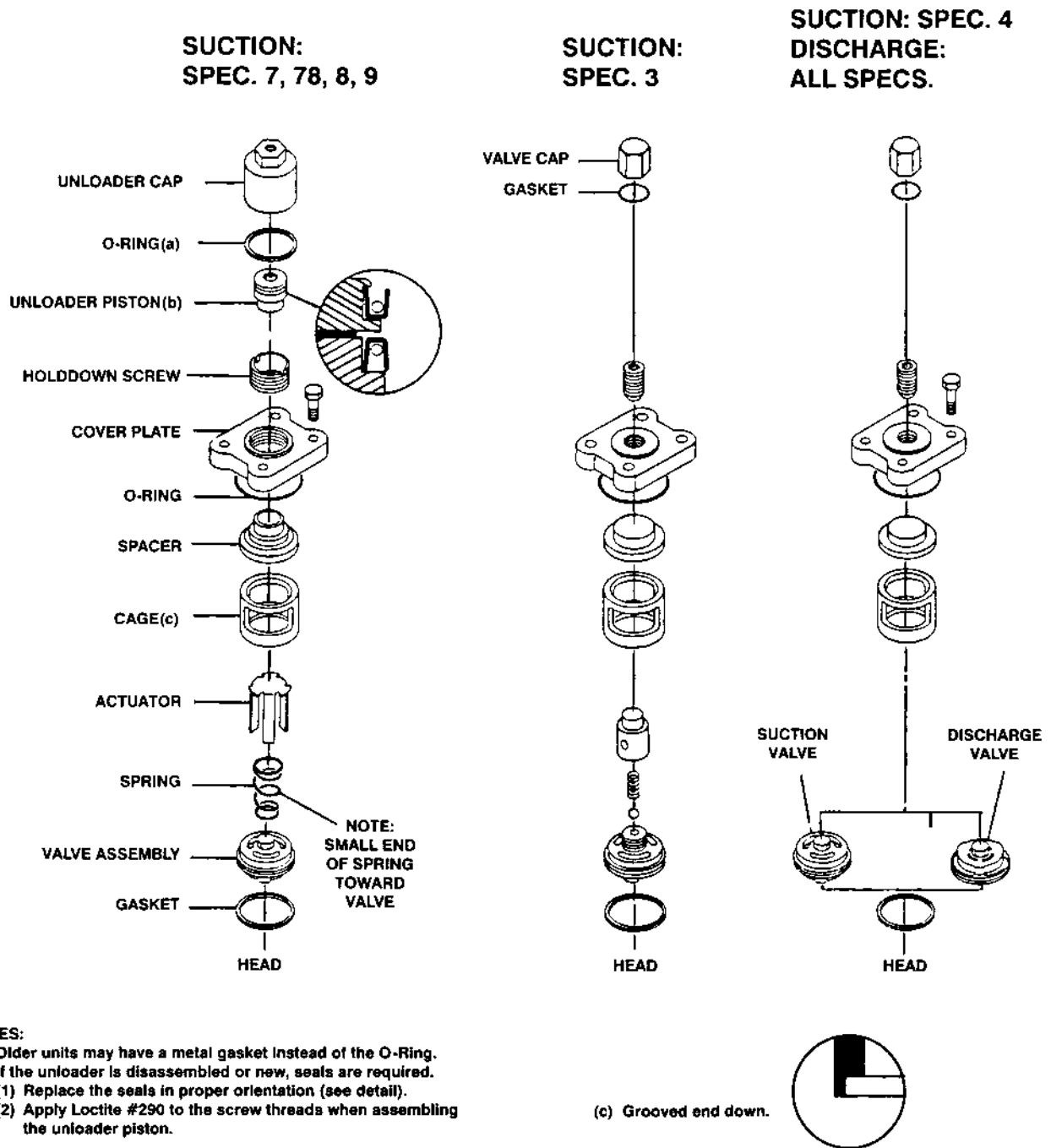

**FIGURE 5.1B**

Inspect valves for breakage, corrosion, scratches on the valve disk and debris. In many cases, valves may simply be cleaned and reinstalled. If valves show any damage, they should be repaired or replaced. Replacement is usually preferable, although repair parts are available. If valve disks are replaced, seats

should also be lapped until they are perfectly smooth. If more than .005" must be removed to achieve a smooth surface, the valve should be discarded. If disks are replaced without relapping the seat, rapid wear and leakage will occur.

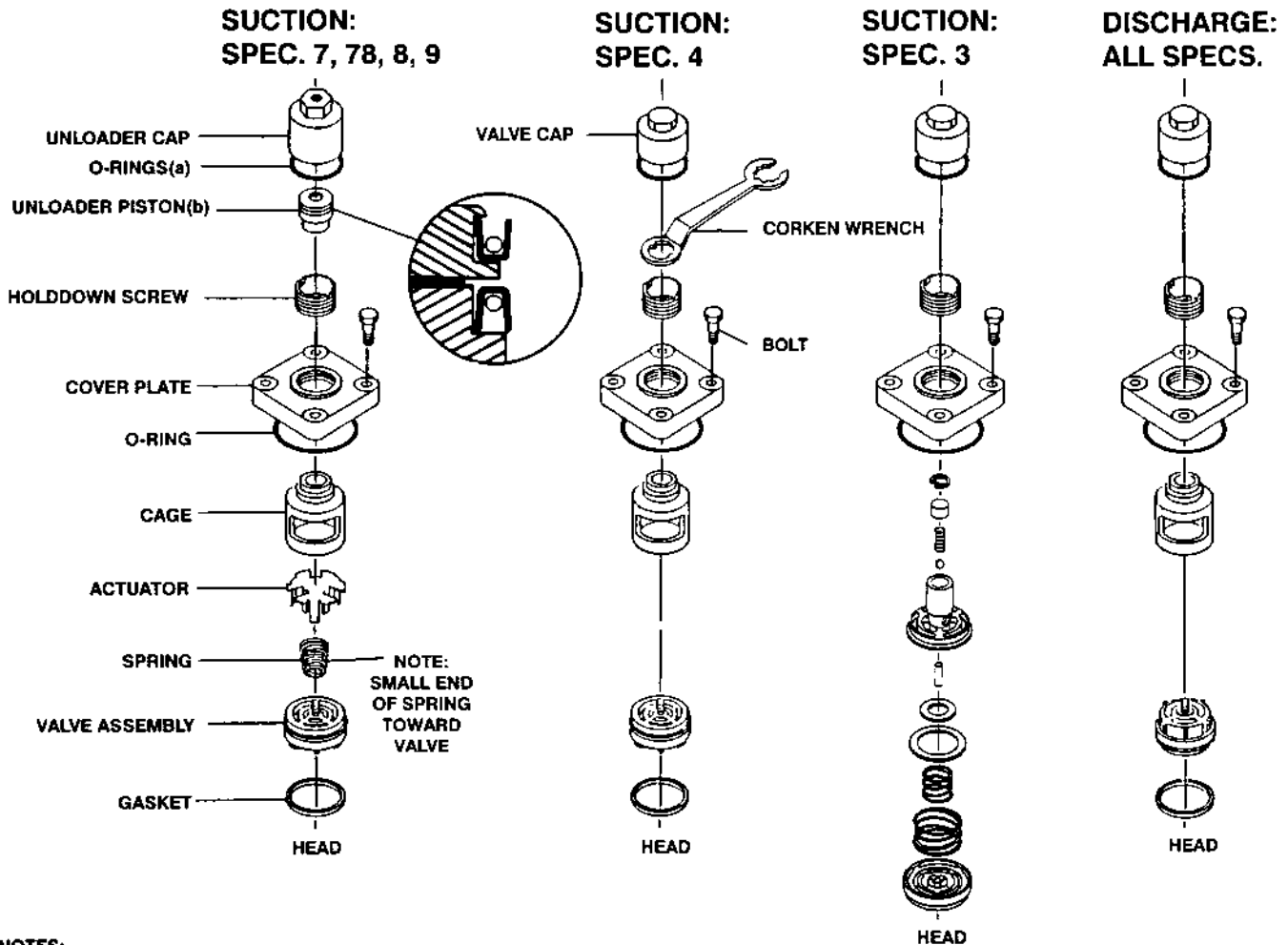

**NOTES:**

- (a) Older units may have a metal gasket instead of the O-Ring.
- (b) If the unloader is disassembled or is new, seals are required
  - (1) Replace the seals in proper orientation (see detail)
  - (2) Apply Loctite #290 to the screw threads when assembling the unloader piston.

**FIGURE 5.1C**

The metal valve gasket should always be replaced when the valve is reinstalled. Make sure suction and discharge valves are in the right slots, as shown in the illustrations. Reinstall cages, spacers or unloader parts and then tighten the valve hold down screw to 40 ft./lb. to ensure the valve gasket is properly seated. Replace O-rings sealing the valve cover and valve cap if they show any signs of wear or damage. Reinstall valve caps sealed by flat metal gaskets with new gaskets. Refer to Appendix D for torque values.

\*Some Spec. 3 suction valves have an adjusting screw to set the liquid relief pressure. To adjust, tighten the adjusting screw until it bottoms, then back off one and a half turns on the size 491 only.

## 5.2 CYLINDERS AND HEAD

Cylinders and heads very seldom require replacement if the compressor is properly maintained. The primary causes of damage to cylinders and heads are corrosion and the entry of solid debris or liquid into the compression chamber. Improper storage can also result in corrosion damage to the head and cylinder (for proper storage instructions see Section 5.8).

If the cylinder does become damaged or corroded, use a hone to smooth the cylinder bore, then polish it to the value shown in Appendix E. If more than .005" must be removed to smooth the bore, replace the cylinder. Cylinder liners and oversized rings are not available. Overboring the cylinder will result in greatly reduced ring life.

Many compressor repair operations require removal of the head and cylinder. While the compressor is disassembled, take special care to avoid damage or corrosion to the head and cylinder. If the compressor will be left open for more than a few hours, coat bare metal surfaces with rust preventative.

When reassembling the compressor, make sure the bolts are retightened as shown in Appendix D.

## 5.3 PISTON RINGS AND PISTON RING EXPANDERS

Piston ring life will vary considerably from application to application. Ring life will improve dramatically at lower speeds and temperatures or lubricated service.

To replace the piston rings: Depressurize the compressor and purge if necessary. Remove the head to gain access to the compressor cylinder. Loosen the piston head bolts. Remove the piston as

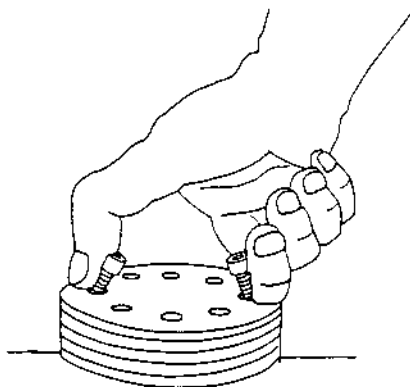

FIGURE 5.3A

shown in Figure 5.3A, by pinching two loose bolts together. Piston rings and expanders may then be easily removed and replaced. Corken recommends replacing expanders whenever rings are replaced.

To determine if rings should be replaced, measure the radial thickness and compare it to the chart in Appendix E. Rings should be replaced if they are near the minimum listed in Appendix E.

## 5.4 PISTONS

To replace the pistons: *Depressurize the compressor and purge if necessary.* Remove the compressor cylinder and head (see Section 5.2). Remove the piston head by loosening and removing the socket head bolts holding the piston head to the piston platform (see Figure 5.3A). Next, remove the roll pin with needle nose pliers. The castellated nut may now be removed and the piston platform lifted off the end of the piston rod. Check the thrust washer and shims for damage and replace if necessary.

Note: On model 151 (Stage 2) use compressor wrench to remove piston from rod. No piston nut, roll pin or bolts are required. Apply loctite to piston rod threads prior to re-assembly.

## PISTON CROSS-SECTION SIZES 91 THROUGH 491

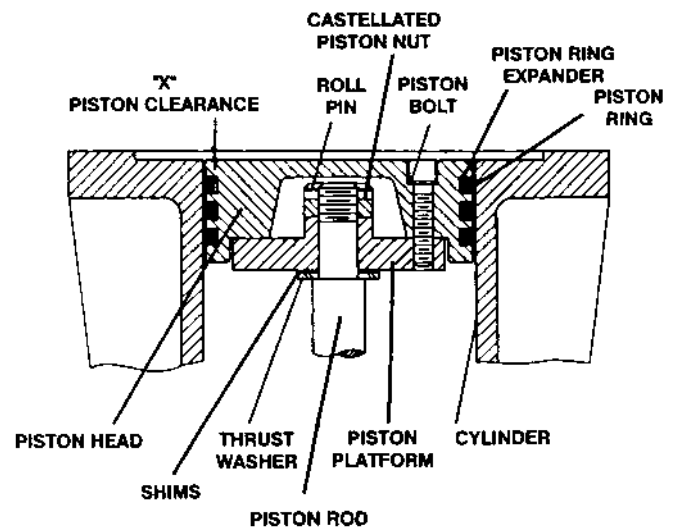
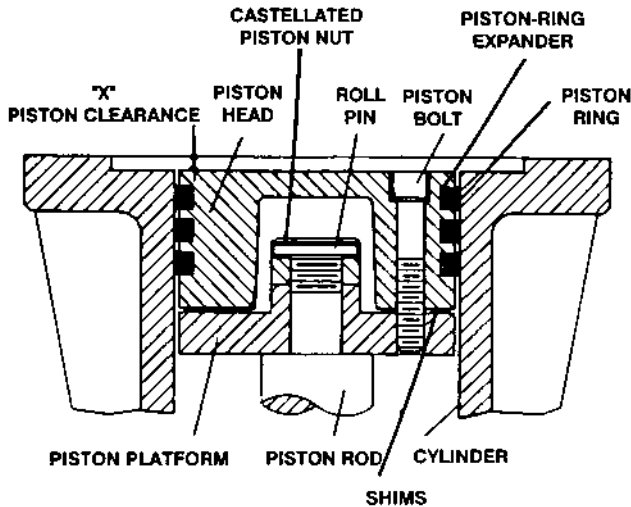

FIGURE 5.4A

**PISTON CROSS-SECTION  
SIZES 590 THROUGH 691**



**FIGURE 5.4B**

Before installing the new piston, measure the thickness of the existing shims. For Models 90 through 491, the shims are placed between the thrust washer and piston platform. For sizes 590 through 691, the shims are placed between the platform and piston head (see Figure 5.4A and 5.4B).

Reinstall the piston platform with the same thickness of shims as before, **BUT DO NOT REINSTALL THE ROLL PIN**. Replace the cylinder and install the piston heads with new piston rings and expanders. Now measure dimension "X", shown in the illustration. If this measurement does not fall within the tolerances shown in Appendix E, remove the piston, adjust the shims as necessary and remeasure the "X" dimension. When the piston is properly shimmed, tighten the castellated nut, as shown in Appendix D. Now install a new roll pin to lock the castellated piston nut in place. Install the piston head and tighten the socket head bolts in an alternating sequence. Reinstall the head (see Section 5.5) and follow standard start-up procedure.

**5.5 PISTON-ROD-PACKING  
ADJUSTMENT**

Piston-rod packing should be replaced whenever leakage approaches an unacceptable level. "Acceptable leakage" should be determined by the customers according to safety and environmental regulations for their area. Typically, it is a good idea to replace piston-rod packing and piston rings at the same time.

**PACKING-ADJUSTING NUTS**

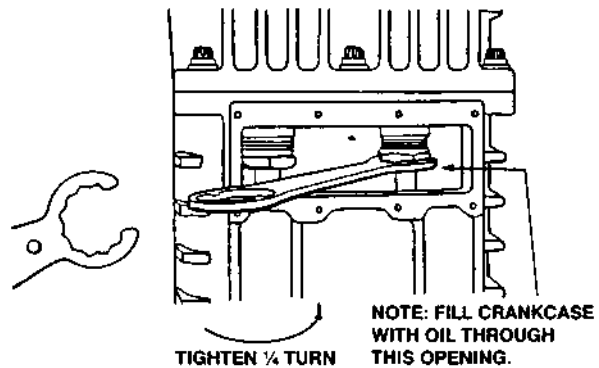

**FIGURE 5.5A**

Instructions for packing replacement are included with each set of packing.

Inspection of the rod packing is generally not productive, since packing that cannot be adjusted to an "acceptable leakage" rate should be replaced.

To adjust the packing, remove the compressor nameplate, tighten the packing-adjusting nut(s) 1/4 turn with the wrench supplied, then run the compressor a few minutes to reseal the packing. If the leakage is still unacceptable, tighten the adjusting nut as necessary, 1/4 turn at a time; do not over-tighten! If the adjusting nut can be tightened until the packing spring is solid, the packing should be replaced. If packing will not seal, carefully inspect piston rods for possible scoring. Replace if needed.

Reattach the compressor nameplate after adjustments or repairs are made.

**5.6 BEARING REPLACEMENT**

To replace the crankcase roller bearings, wrist-pin bushing and connecting-rod bearings, begin by removing the head, cylinder, piston, crosshead guide and crosshead. Drain the crankcase and remove the inspection plates. Loosen and remove the connecting-rod bolts in order to remove the crosshead/connecting-rod assembly.

### 5.6.1 WRIST-PIN BUSHING REPLACEMENT

To replace the wrist-pin bushing, remove the retainer rings that position the wrist pin in the crosshead. Press out the wrist pin so the crosshead and connecting rod may be separated. Inspect the wrist pin for wear and damage and replace if necessary.

Press out the old wrist-pin bushing and press a new bushing into the connecting rod. **DO NOT MACHINE THE O.D. OR I.D. OF THE BUSHING BEFORE PRESSING INTO CONNECTING ROD.** Make sure the lubrication hole in the bushing matches the oil passage in the connecting rod. If the holes do not align, drill out the bushing through the connecting-rod lubricant passage with a long drill. Bore the wrist-pin bushing I.D. as indicated in Appendix E. Overboring the bushing can lead to premature failure of the wrist-pin bushing. Inspect the oil passage for debris; clean thoroughly before proceeding. Press the wrist pin back into the crosshead and reinstall retainer rings. **NOTE:** The fit between the wrist pin and bushing is tighter than on ordinary lubricated air compressors or combustion engines.

### 5.6.2 CONNECTING-ROD BEARINGS

Connecting-rod bearings are easily replaced after removing the semicircular inserts. Make sure the indentations in the connecting-rod bearing and connecting rod line up when installing the new bearings.

Before reinstalling the crosshead/connecting-rod assembly, make sure the crankshaft throw and bearing surface are clean and lubricated. Tighten the connecting-rod bolts to the torques listed in Appendix D.

### 5.6.3 ROLLER BEARINGS

To inspect the roller bearings, remove the flywheel from the crankshaft, then remove the bearing carrier and crankshaft from the crankcase. If corrosion or pitting is present, replace the roller bearing. When replacing roller bearings, always replace the entire bearing, not just the cup or the cone.

To replace the bearings, press the cups out of the crankcase and bearing carrier and press the cones off the crankshaft. Press the new bearings into position and reassemble the crankshaft and bearing carrier to the crankcase. When reinstalling the

### BEARING - CARRIER REPLACEMENT

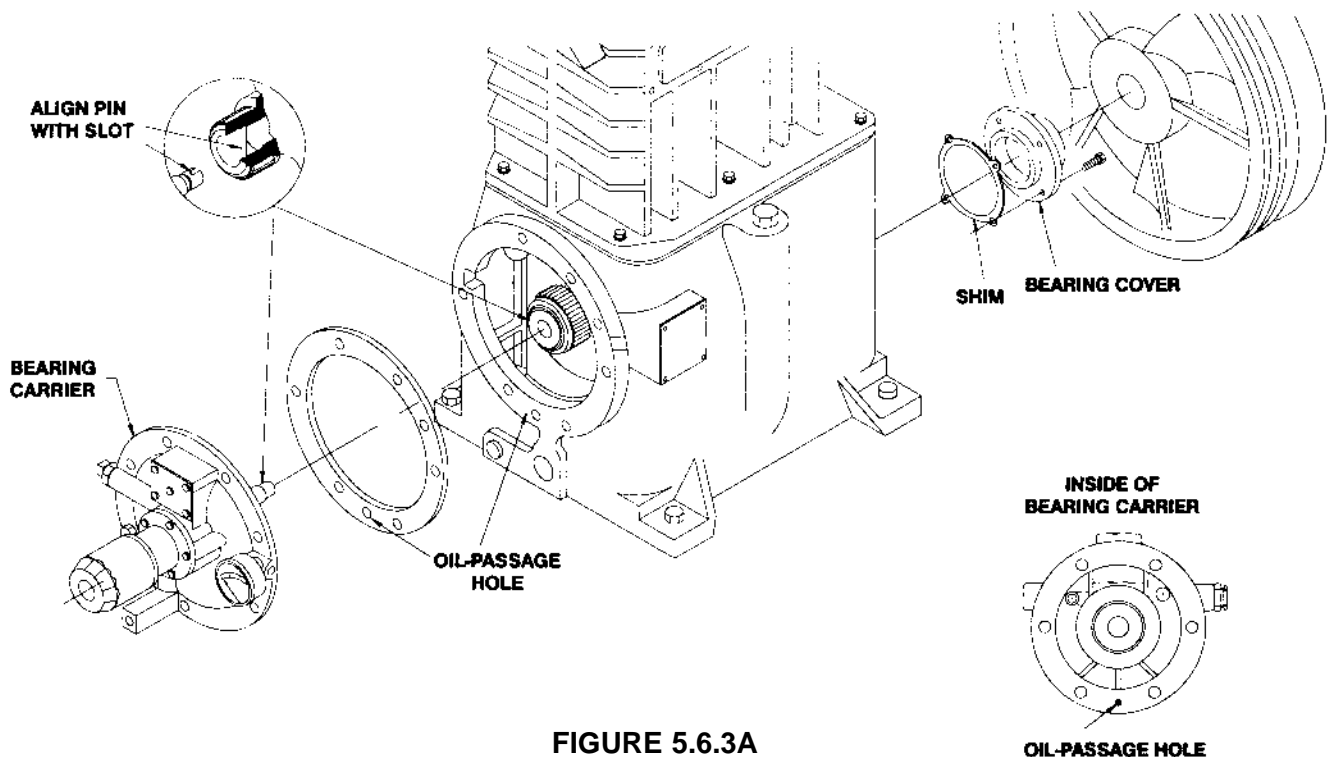

FIGURE 5.6.3A



## CHAPTER 6

### EXTENDED STORAGE PROCEDURES

Following a few simple procedures will greatly minimize the risk of the unit becoming corroded and damaged. Corken recommends the following precautions to protect the compressor during storage:

1. Drain the crankcase oil and refill with rust-inhibiting oil.
2. Operate for a few minutes while fogging oil into the compressor suction.
3. Relieve V-belt tension.
4. Plug all openings to prevent entry of insects and moisture. (The cylinders may also be protected with a vapor phase inhibitor, silica gel, or dry nitrogen gas. If silica gel is used, hang a tag on the unit indicating that it must be removed before a start-up.)
5. Store in a dry area, off the ground if possible.
6. Rotate the flywheel every two weeks if possible.

CHAPTER 7

INSTALLATION OF LIQUEFIED GAS TRANSFER COMPRESSORS

7.1 STATIONARY COMPRESSORS

Corken supplies its single-stage compressors in the 107-Style mounting for the transfer of liquefied gases (Figure 7.1A). The compressor suction and discharge are connected through a four-way valve. When the four-way valve is in position one (Figure 7.1B), the compressor can be used to create a differential pressure between the vapor spaces of two tanks of liquid. This induces a liquid flow through

a separate liquid line to unload one tank into the other. In position two (Figure 7.1C), vapor can be evacuated from one tank to the other (note that the liquid line should be shut off in position 2). The vapor is discharged to the storage tank in the liquid phase to recondense the vapor to liquid. (See Corken publication CP226, *Guide to Corken Liquefied Gas Transfer Equipment*, for more information.)

107 STYLE COMPRESSOR MOUNTING

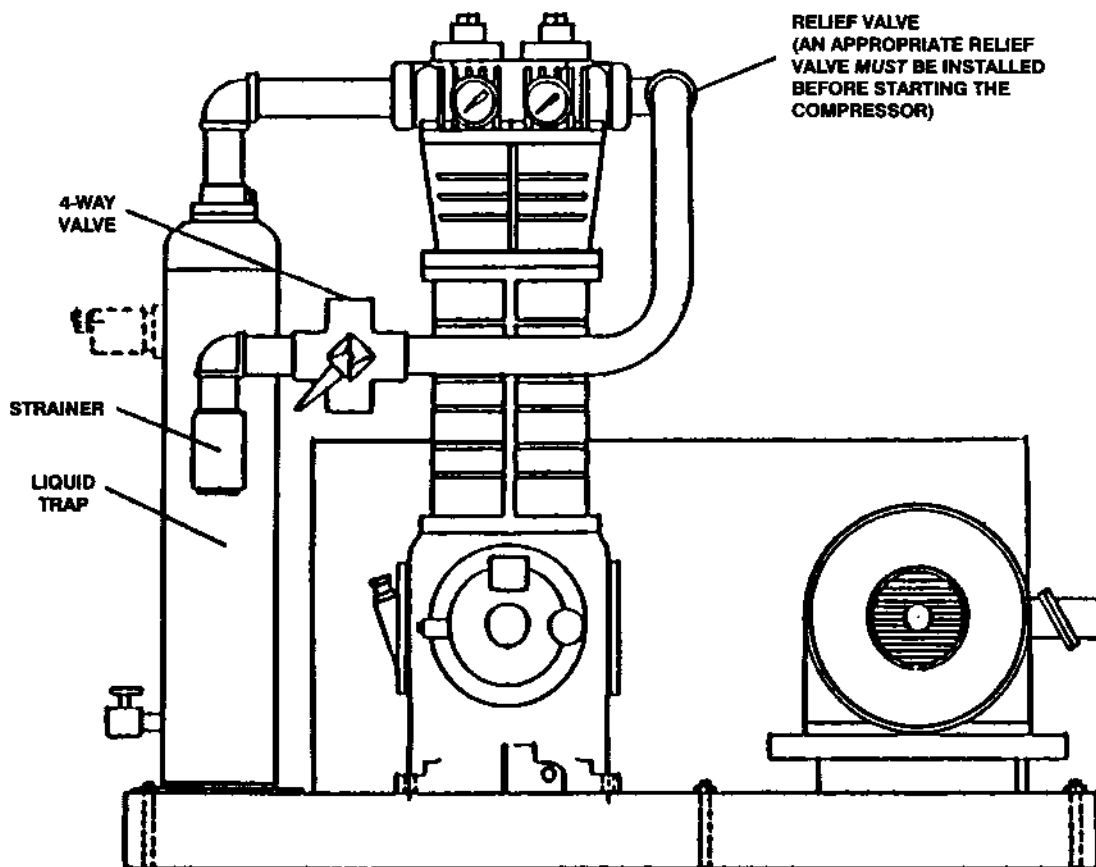
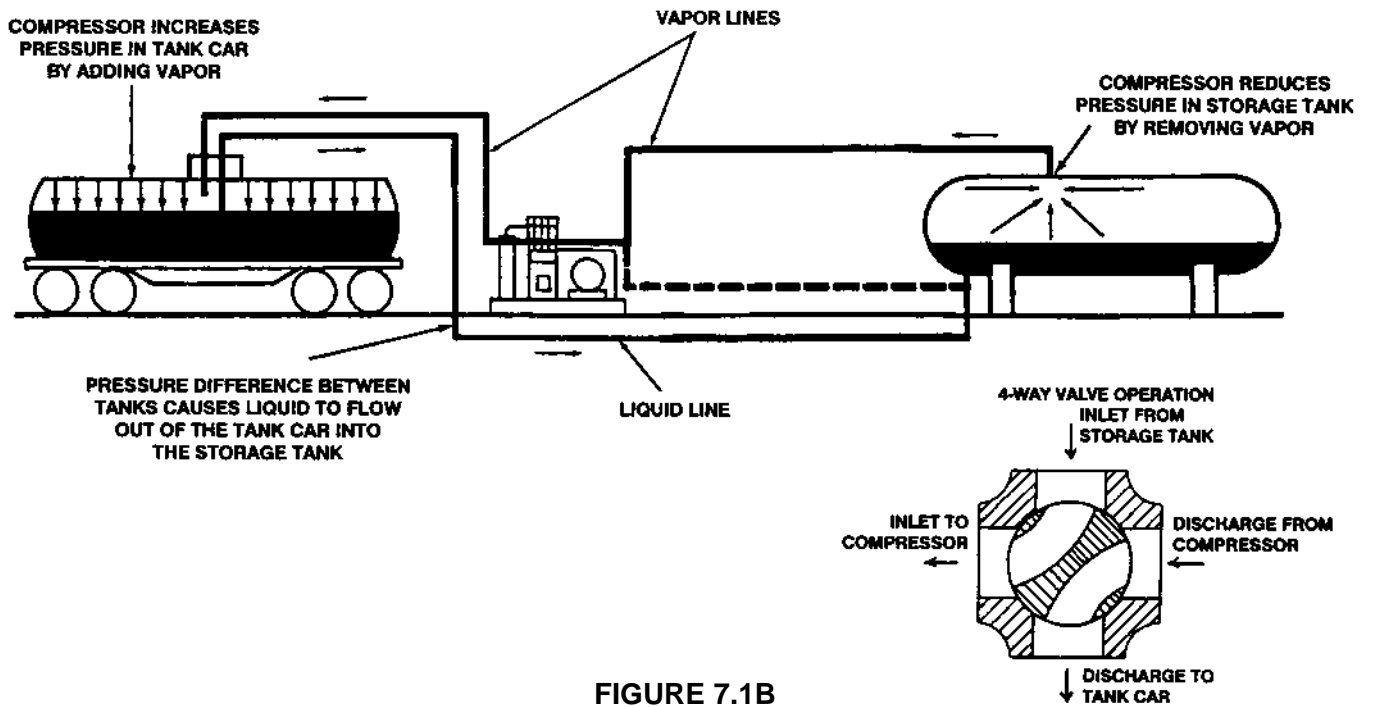

FIGURE 7.1A

**POSITION 1**



**FIGURE 7.1B**

**POSITION 2**

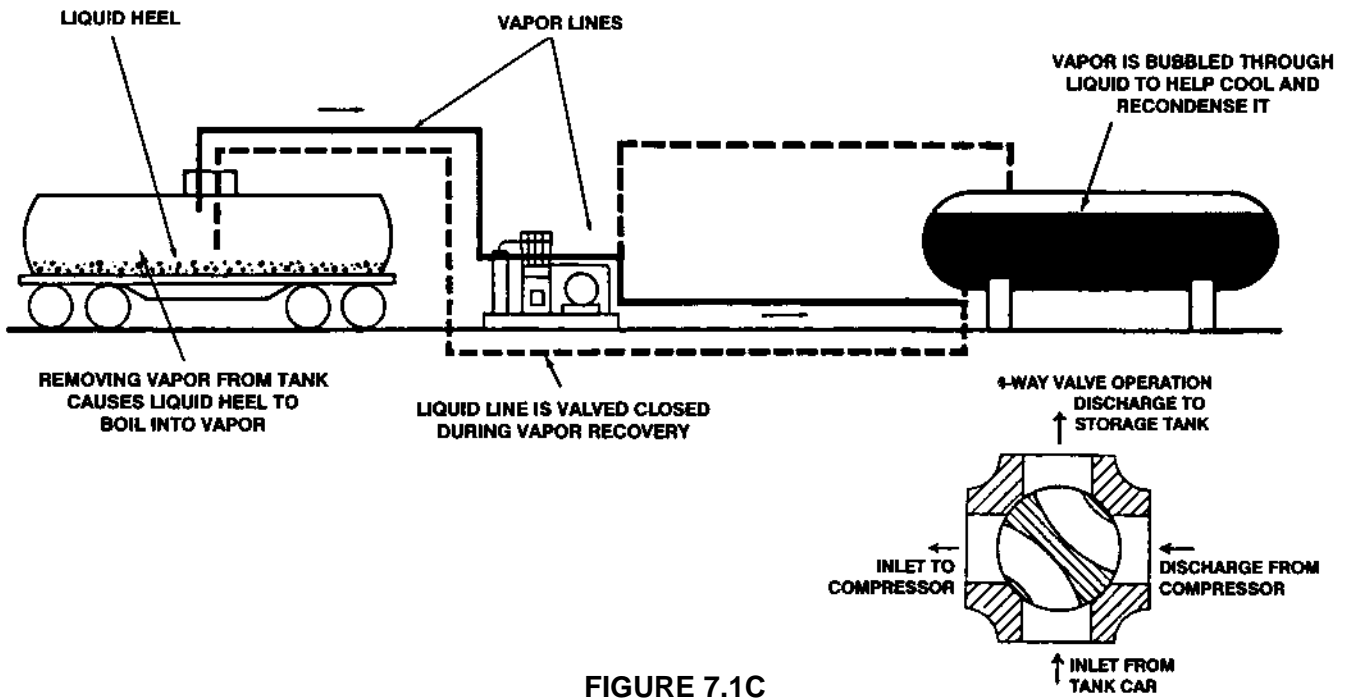
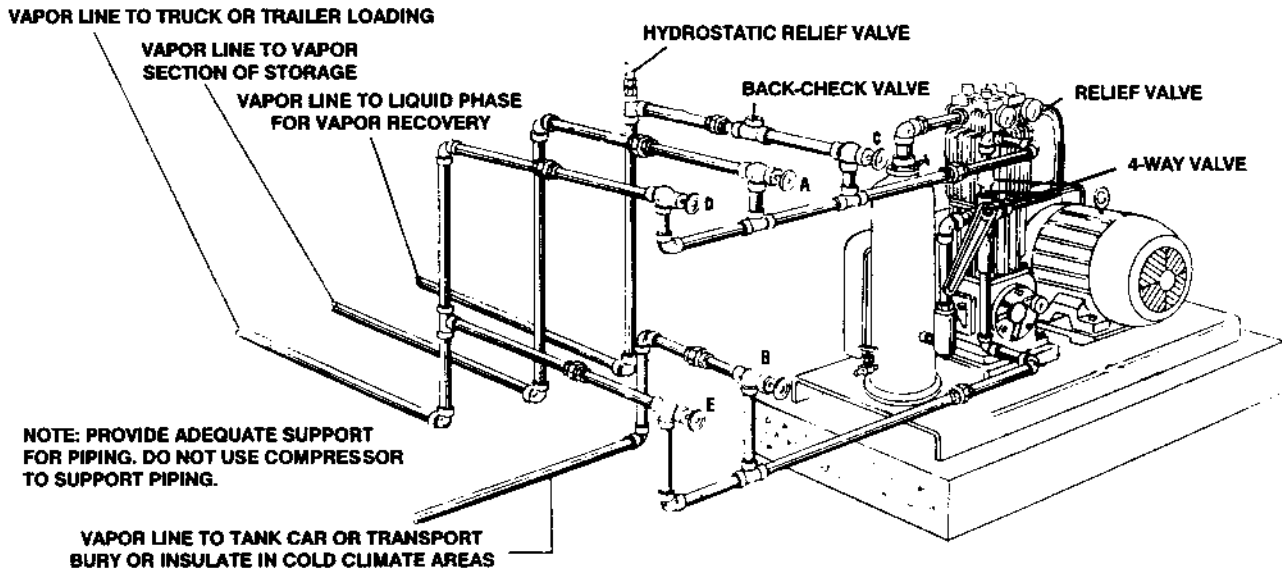

**FIGURE 7.1C**

107 Style compressors are usually connected using a five-valve (Figure 7.1D) or three-valve manifold (Figure 7.1E). The five-valve manifold allows the storage tank to be both loaded and unloaded. The

three-valve manifold only allows the storage tank to be loaded. Adequate sizing of the liquid and vapor lines is essential to limit the pressure drop in the system to a reasonable level (20 psi or less).

### FIVE-VALVE MANIFOLD PIPING SYSTEM



### OPERATION OF VALVES

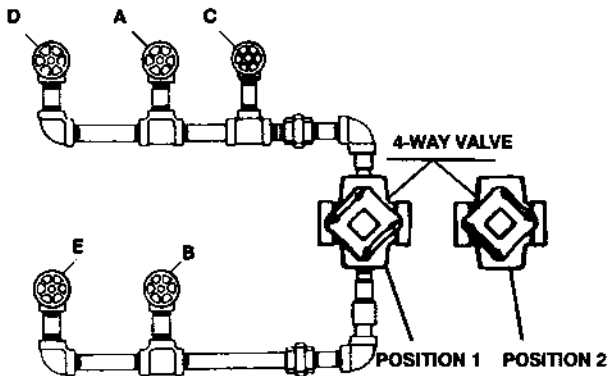

SERVICE TO PERFORM	VALVE POSITION					
	4-WAY	A	B	C	D	E
1. Unload Tank Car into Storage Tank	Position One	Open	Open	Close	Close	Close
2. Recover Vapors from Tank Car into Storage Tank	Position Two	Close	Open	Open	Close	Close
3. Unload Transport or Truck into Storage Tank	Position One	Open	Close	Close	Close	Open
4. Recover Vapors from Transport or Truck into Storage Tank	Position Two	Close	Close	Open	Close	Open
5. Load Truck or Field Tank from Storage Tank	Position Two	Open	Close	Close	Close	Open
6. Load Truck or Field Tank from Tank Car	Position One	Close	Open	Close	Open	Close
7. Equalize Between Tank Car and Storage Tank Without using Vapor Pump	---	Open	Open	Close	Open	Open
8. Equalize Between Truck or Field Tank and Storage Tank Without Using Vapor Pump	---	Open	Close	Close	Open	Close

FIGURE 7.1D

### THREE-VALVE MANIFOLD PIPING SYSTEM

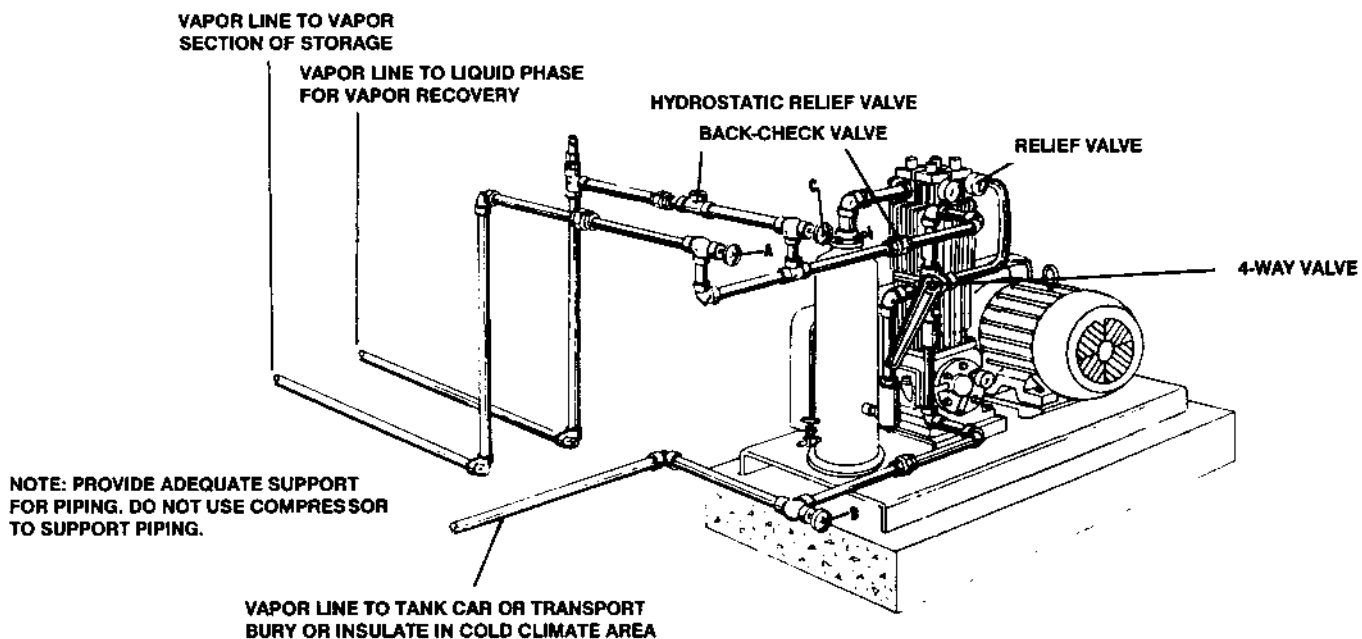

### OPERATION OF VALVES

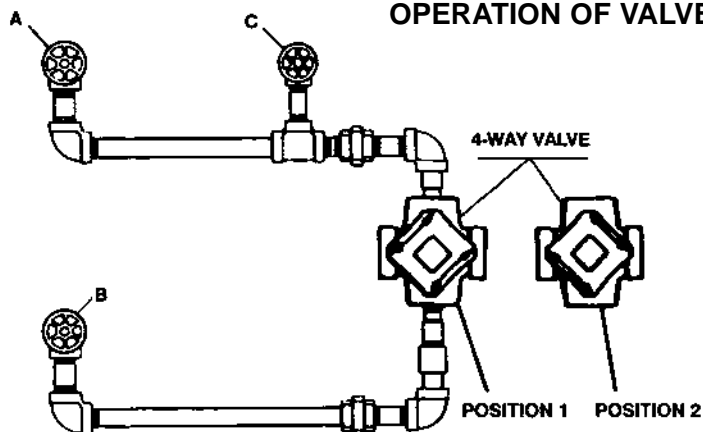

SERVICE TO PERFORM	VALVE POSITION			
	4-WAY	A	B	C
1. Unload Tank Car into Storage Tank	Position One	Open	Open	Close
2. Recover Vapors from Tank Car into Storage Tank	Position Two	Close	Open	Open

FIGURE 7.1E

PLANT CAPACITY	PIPE SIZE (INCHES)	
	VAPOR PIPING	LIQUID PIPING
Up to 40 (150)	3/4	1-1/4
Up to 50 (190)	1	1-1/2
Up to 80 (300)	1-1/4	2
Up to 90 (340)	1-1/4	2-1/2
Up to 200 (755)	1-1/2	3
Up to 350 (1325)	2	4

FIGURE 7.1F

Figure 7.1F shows recommended pipe sizes for liquid and vapor piping. For line lengths over 100 ft. (30 meters), the next larger pipe size should be used.

Line size helps determine plant capacity almost as much as the size of the compressor does, and liquid line sizes are a bigger factor than vapor lines. If the pressure gauges on the head indicate more than a 15 to 20 psi (2.07 to 2.40 Bars) differential between inlet and outlet pressures, the line sizes are too small or there is some fitting or excess flow valve creating too much restriction. The less restriction in the piping, the better the flow.

A tank-car-unloading riser should have two liquid hoses connected to the car liquid valves. If only one liquid hose is used, the transfer rate will be slower and there is a good possibility that the car's excess flow valve may close.

Since the heat of compression plays an important part in rapid liquid transfer, the vapor line from the compressor to the tank car or other unloading container should be buried or insulated to prevent the loss of heat. In extremely cold climates, if the line from the storage tank to the compressor is over 15 feet (4.6 meters) long, it should be insulated also to lessen the possibility of vapors condensing as they flow to the compressor. The vapor-recovery-discharge line is better not insulated. Placing the compressor as close as possible to the tank being unloaded will minimize heat loss from the discharge line for the best liquid transfer rate.

Unloading tanks with a compressor is quite practical. Delivery trucks and other large containers can be filled rapidly if the vapor system of the tank to be filled will permit fast vapor withdrawal, and if the liquid-piping system is large enough. Many older

trucks (and some new ones) are not originally equipped with vapor-excess flow valves large enough to do a good job; these should be replaced by a suitable size valve. The liquid discharge should be connected to the tank-truck pump inlet line rather than the often oversized filler-valve connection in the tank head.

It is of extreme importance to prevent the entry of liquid into the compressor. The inlet of the compressor should be protected from liquid entry by a liquid trap (see Section 2.4). It is of equal importance to protect the discharge of the compressor from liquid. This may be done by installing a check valve on the discharge and designing the piping so liquid cannot gravity-drain back into the compressor. Make sure to install a check valve on vapor lines discharging to the liquid space of the tank.

All piping must be in accordance with the laws and codes governing the service. In the United States, the following codes apply:

**For L.P. Gas** - The National Fire Protection Association Pamphlet No. 58, *Standard for the Storage and Handling of Liquefied Petroleum Gases*.

**For Ammonia** - The American National Standards Institute, Inc., K61.1-1972. *Safety Requirements for the Storage and Handling of Anhydrous Ammonia*.

Copies of these are available from NFPA, 60 Batterymarch Street, Boston, Mass., 21100 and ANSI, 1430 Broadway, New York, N.Y., 10018. Install, use and maintain this equipment according to Corken instructions and all applicable federal, state, local laws and previously mentioned codes.

## 7.2 TRUCK-MOUNTED COMPRESSORS

Corken compressors are frequently mounted on trucks to perform liquid transfer operations as described in Section 7.1. The compressor should be mounted so the inspection plate is accessible for packing adjustment. The compressor must be protected against liquid, as explained in Section 7.1, and a relief valve must be installed in the discharge piping before the first downstream shutoff valve.

**INSIDE-TRANSPORT MOUNTING**

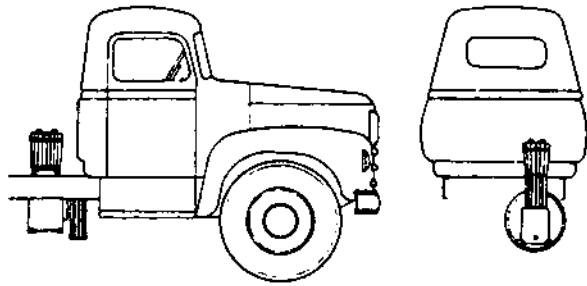

**FIGURE 7.2A**

**OUTSIDE-TRANSPORT MOUNTING**

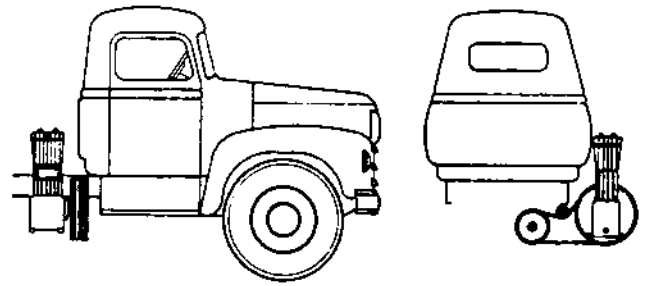

**FIGURE 7.2C**

**U-JOINT DRIVE FOR COMPRESSOR**

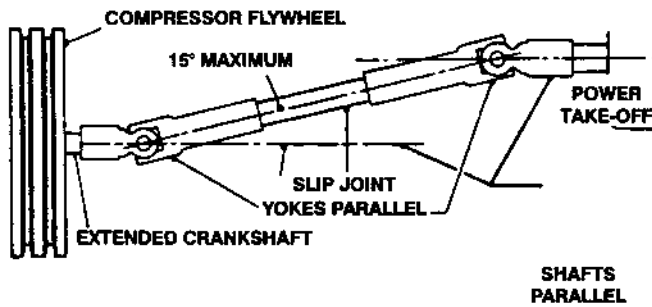

**FIGURE 7.2B**

**TOP-TRANSPORT MOUNTING**

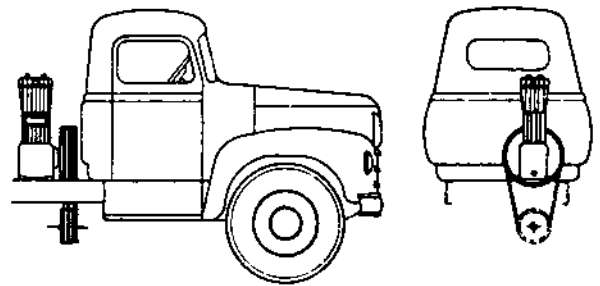

**FIGURE 7.2D**

Three types of mountings are typically used. The inside mounting (Figure 7.2A) drives the compressor directly off the PTO shaft. The PTO must be selected to drive the compressor between 400 and 800 RPM. An extended compressor crankshaft is required so the U-joint yoke may connect to the compressor without removing the flywheel. **Do not operate the compressor without a flywheel.** Use a U-joint with a splined joint and make sure the connections are parallel and in line. The U-joint angle should be less than 15 degrees (see Figure 7.2B). Always use an even number of U-joints.

Depending on the truck design, the compressor may be outside- or top-mounted, as shown in Figures 7.2C and D, to be V-belt driven. Power is transmitted through a U-joint drive shaft, jackshaft with two pillow-block bearings, V-belt sheave and V-belts. An idle pulley may be used under the truck frame.

MODEL NUMBER AND MOUNTING IDENTIFICATION CODE

MODELS INVOLVED	DESCRIPTION	CODE	FEATURE		EXAMPLE
ALL 391, 591, 691, 691-4	AIR COOLED WATER COOLED	NONE W	COOLING	W	MODEL NUMBER
ALL	ANSI-DIN FLANGE INLET AND OUTLET		HEAD CONNECTION STYLE	F	
ALL ALL	SINGLE DISTANCE PIECE DOUBLE DISTANCE PIECE	D T	DISTANCE PIECE DESIGN	T	
	SINGLE-STAGE, DUCTILE IRON	91 291 491/492 491-3 691/692 691-4	BASIC MODEL	591	
	TWO-STAGE, DUCTILE IRON	191 391 591			
ALL EXCEPT T-STYLE ALL EXCEPT T-STYLE ALL T-STYLE ALL T-STYLE	INLET PRESSURE ABOVE ATMOSPHERIC ATMOSPHERIC INLET OR VACUUM SERVICE STANDARD PACKING ARRANGEMENT FOR T-STYLE PACKING ARRANGED FOR PURGING OF DISTANCE PIECE	A B G H	PACKING ARRANGEMENT	H	
91 ONLY 91-491 ALL EXCEPT 91 ALL EXCEPT 91 ALL EXCEPT 91 ALL EXCEPT 91	SPLASH LUBRICATED CRANKCASE EXTENDED CRANKSHAFT STANDARD PRESSURE LUBRICATED CRANKCASE STANDARD CRANKCASE WITH CRANKCASE HEATER STANDARD CRANKCASE WITH EXTERNAL COMPRESSOR LUBRICATOR STANDARD CRANKCASE WITH EXTERNAL COMPRESSOR LUBRICATOR AND CRANKCASE HEATER	J E M MH L LH	CRANKCASE STYLE	M	
ALL ALL ALL EXCEPT 91	LIQUID RELIEF SUCTION VALVES STANDARD SUCTION AND DISCHARGE VALVES LOADLESS START THROUGH SUCTION VALVE UNLOADERS AND HYDRAULIC UNLOADER (BRASS - VENTS TO ATMOSPHERE)	3 4 7	VALVES	9	
ALL	CONSTANT SPEED UNLOADING THROUGH SUCTION VALVE UNLOADERS AND PILOT VALVE (BRASS - VENTS TO ATMOSPHERE)	8			
ALL EXCEPT 91	COMBINATION CONTROL: INCLUDES LOADLESS STARTING AND CONSTANT SPEED UNLOADING	78			
ALL 391-491 SERIES	SUCTION VALVE UNLOADERS SPEC 3 VALVES AS NOTED ABOVE WITH MC1002 CORROSION RESISTANT COATING	9 3C			
391-491 SERIES	SPEC 4 VALVES AS NOTED ABOVE WITH MC1002 CORROSION RESISTANT COATING	4C			
391-491 SERIES	SPEC 9 VALVES AS NOTED ABOVE WITH MC1002 CORROSION RESISTANT COATING	9C			
ALL EXCEPT 391-491 ALL EXCEPT 391-491	SPEC 4 VALVES AS NOTED ABOVE WITH PEEK VALVE PLATES SPEC 9 VALVES AS NOTED ABOVE WITH PEEK VALVE PLATES	4P 9P			
91-491 SERIES 591-691 SERIES ALL ALL ALL ALL ALL ALL	PTFE PISTON RING AND PACKING MATERIAL PTFE PISTON RING AND ALLOY 50 PACKING MATERIAL SAME AS F WITH ADDITION OF K-RING SPACERS ALLOY 50 PISTON RINGS AND PACKING MATERIAL SAME AS G WITH THE ADDITION OF K-RING SPACERS PEEK PISTON RING AND ALLOY 50 PACKING MATERIAL SAME AS H WITH THE ADDITION OF K-RING SPACERS SPECIAL PISTON RING AND PACKING MATERIAL	F FK G GK H HK Z	PISTON RING AND PACKING MATERIAL	F D	
ALL ALL ALL	ALUMINUM GASKET MATERIAL COPPER GASKET MATERIAL IRON-LEAD GASKET MATERIAL	B C D	GASKET MATERIAL	E	
ALL ALL ALL ALL ALL	BUNA-N NEOPRENE* VITON* PTFE SPECIAL	A B D E Z	O-RING MATERIAL		
ALL AIR-COOLED TWO-STAGE COMPRESSORS EXCEPT 591 ALL AIR-COOLED TWO-STAGE COMPRESSORS EXCEPT 591 ALL TWO-STAGE ALL TWO-STAGE ALL TWO-STAGE EXCEPT 591 ALL TWO-STAGE ALL TWO-STAGE ALL TWO-STAGE ALL TWO-STAGE ALL SINGLE-STAGE ALL TWO-STAGE	AIR-COOLED IRON (RATED FOR 625 PSI) AIR-COOLED COPPER (RATED FOR 625 PSI) WATER-COOLED BRASS (RATED FOR 150 PSI) WATER-COOLED STAINLESS STEEL (RATED FOR 200 PSI) HEAVY DUTY AIR COOLED COPPER (RATED FOR 500 PSI) NPT FLANGES ONLY - NO INTERCOOLER COOLING LOOP COPPER COOLING LOOP STAINLESS STEEL N/A - SINGLE STAGE COMPRESSOR (NO INTERCOOLER) SPECIAL INTERCOOLER	A B C D E F G H N Z	INTERCOOLER	F	
191-491 SERIES	14" FLYWHEEL USED IN CONJUNCTION WITH EXTENDED CRANKSHAFT	E	FLYWHEEL	S	
91-491 SERIES ALL ALL	HEAVY DUTY FLYWHEEL NO FLYWHEEL SUPPLIED STANDARD FLYWHEEL	H N S			
ALL ALL ALL	COATED CYLINDER ONLY NO COATING COATING ON ALL NECESSARY WETTED PARTS	C N W	PROTECTIVE COATING	W	
ALL ALL ALL	CHROME OXIDE PISTON ROD COATING NITROTEC PISTON ROD COATING (STANDARD) SPECIAL PISTON ROD COATING (CONSULT FACTORY)	C N Z	PISTON ROD COATING	N	

APPENDIX A

Distributed by Industrial Gas Technology, Inc. - www.industrialgastech.com  
**MATERIAL SPECIFICATIONS**

PART	STANDARD		OPTIONAL	
	SIZE	MATERIAL	SIZE	MATERIAL
HEAD, CYLINDER	590, 690, 690-4	GRAY IRON ASTM A48, CLASS 30		
	91, 191, 291, 391, 491, 691	DUCTILE IRON ASTM A536	492-692	DUCTILE IRON DIN 1693 666-40.3
DISTANCE PIECE, CROSSHEAD GUIDE CRANKCASE, FLYWHEEL BEARING CARRIER	ALL	GRAY IRON ASTM A48, CLASS 30		
FLANGE	590, 691	DUCTILE IRON ASTM A536	590, 690, 691, 690-4	STEEL WELDING
VALVE SEAT AND BUMPER	91, 191, 291	17-7 PH STAINLESS STEEL		
	391, 491, 490-3	DUCTILE IRON ASTM A536		
	590, 691	STAINLESS STEEL		
VALVE PLATE	91, 191, 291	410 STAINLESS STEEL	91, 191, 291	PEEK
	391, 491, 490-3	17-7 PH STAINLESS STEEL		
	590, 691	STAINLESS STEEL	590, 691	PEEK
VALVE SPRING	91, 191, 291, 590, 691	17-7 PH STAINLESS STEEL		
	391, 491, 490-3	INCONEL		
VALVE GASKETS	ALL	SOFT ALUMINUM	ALL	COPPER, IRON-LEAD
PISTON	91, 191, 291, 391, 491, 590, 691 590, 691	GRAY IRON ASTM A48, CLASS 30		
PISTON ROD	ALL	C1050 STEEL, NITROTEC, ROCKWELL 60C	ALL D & T STYLE MODELS	CHROM OXIDE COATING
CROSSHEAD	ALL	GRAY IRON ASTM A48, CLASS 30		
PISTON RINGS	ALL	PTFE, GLASS AND MOLY FILLED OR ALLOY 50	ALL	SPECIAL ORDER MATERIALS AVAILABLE
PISTON RING EXPANDERS	ALL	302 STAINLESS STEEL		NONE
HEAD GASKET	590	CELLULOSE FIBER	590	GRAFOIL
	91, 191, 290, 291, 391, 491, 691 491, 691	O-RING (BUNA-N)	91, 191, 290, 291, 391, 491, 691	PTFE, VITON*, NEOPRENE*
ADAPTER PLATE, PACKING CARTRIDGE, CONNECTING ROD	ALL	DUCTILE IRON ASTM A536		
PACKING RINGS	ALL	PTFE, BRASS AND MOLY FILLED OR ALLOY 50		SPECIAL ORDER MATERIALS AVAILABLE
CRANKSHAFT	ALL	DUCTILE IRON ASTM A536		
CONNECTING ROD BEARING	ALL	BIMETAL D-2 BABBIT		
WRIST PIN	ALL	C1018 STEEL, ROCKWELL 62C		
WRIST PIN BUSHING	ALL	BRONZE SAE 660		
MAIN BEARING	ALL	TAPERED ROLLER		
INSPECTION PLATE	ALL	ALUMINUM		
O-RINGS	ALL	BUNA-N	ALL	PTFE, VITON*, NEOPRENE*
RETAINER RINGS	ALL	STEEL		
MISCELLANEOUS GASKETS	ALL	COROPRENE		

\* VITON AND NEOPRENE ARE REGISTERED TRADEMARKS OF DUPONT.

**APPENDIX B**

MECHANICAL SPECIFICATIONS

Specifications	Single-Stage							Two-Stage				
	91, D91	290, D290	291, D291	491, D491, T491	490-3, D490-3 T490-3	691, D691	690-4 D690-4 WD690-4	151	191, D191	39, D391 T391	W391, WD391 WT391	590, D590 WD590
Cylinder Bore Inches (cm)												
First Stage	3 (7.62)	3 (7.62)	3 (7.62)	4 (10.16)	3 (7.62)	4.5 (11.43)	4 (10.16)	2.5 (6.35)	3 (7.62)	4.5 (11.43)	4.5 (11.43)	6 (15.25)
Second Stage	--	--	--	--	--	--	--	1.25 (3.18)	1.75 (4.45)	2.5 (6.35)	2.5 (6.35)	3.25 (8.26)
Stroke, Inches (cm)	2.5 (6.35)	2.5 (6.35)	2.5 (6.35)	3 (7.62)	3 (7.62)	4 (10.16)	4 (10.16)	2.5 (6.35)	2.5 (6.35)	3 (7.62)	3 (7.62)	4 (10.16)
Piston Displacement CFM (lit/min)	4(113)	8.0(226)	8.0(226)	17.2(487)	9.8(277)	29.2(827)	23.2(657)	2.8(81)	4.0(113)	11.4(323)	11.4(323)	26.2(742)
Minimum at 400 RPM		6(170)	6(170)	6(170)	6(170)	6(170)	17(481)				8(226)	
Maximum at 825 RPM	8(226)	16(453)	16(453)	36(1019)	20(566)	60(1699)	48(359)	5.8(166)	8(226)	22(623)	22(623)	54(1529)
Max. Allowable Rod Loads LBS (Kg)	3600 (1632.96)	3600 (1632.96)	3600 (1632.96)	4000 (1814.40)	4000 (1814.40)	5500 (2494.80)	5500 (2494.80)	3600 (1632.96)	3600 (1632.96)	4000 (1814.40)	4000 (1814.40)	5500 (2494.80)
*Minimum Inlet Pressure, psia (Bars)	3 (.21)	3 (.21)	3 (.21)	3 (.21)	3 (.21)	3 (.21)	3 (.21)	3 (.21)	3 (.21)	3 (.21)	3 (.21)	3 (.21)
*Maximum Pressure psia (Bars)	350 (24.14)	280 (19.31)	350 (24.14)	350 (24.14)	515 (35.52)	350 (24.14)	365 (25.18)	CF	515 (35.52)	515 (35.52)	1000 (70.00)	365 (25.18)
Maximum Motor Size Hp	7.5	15	15	15	15	35	35	15	15	15	15	35
Maximum Outlet Temp °F (°C)	350(177)	350(177)	350(177)	350(177)	350(177)	350(177)	350(177)	350(177)	350(177)	350(177)	350(177)	350(177)

\*These numbers specify pressure-containing abilities of the compressor cylinder and head. For many applications, factors other than the pressure rating will limit the maximum allowable discharge pressure to lower values. These factors include horsepower, temperature and rod load.

APPENDIX C

MODEL (1)	CONN. ROD BOLT FT-LB	BEARING CARRIER FT-LB	BEARING COVER FT-LB	CRANK-CASE INSPEC PLATE FT-LB	X-HEAD GUIDE & DISTANCE PIECE FT-LB	CYL. TO HEAD (2,3) FT-LB	VALVE COVER PLATE BOLT FT-LB	VALVE HOLD-DOWN SCREW (3) FT-LB	PISTON NUT TORQUE FT-LB	PISTON SCREW TORQUE IN-LB	VALVE UNLOADER CAP TORQUE (W/GASKETS) FT-LB	VALVE UNLOADER CAP TORQUE (W/O-RINGS) FT-LB
91	28	38	38	15	30	20	--	40	45	50	40	25
291	28	30	30	13	25	20	--	40	45	50	40	25
151	28	30	30	13	25	CF	--	40	45(ST1) 15(ST2)	35(ST1)	40	25
191	28	30	30	13	25	20	--	40	45(ST1) 15(ST2)	50(ST1) 35(ST2)	40	25
491	30	26	35	8	33	33	35	40	45	100	40	25
391	30	26	35	8	33	33	35	40	45	100(ST1) 35(ST1)	40	25
691/591	40	40	40	9	40	60	37	40	60	100	40	25

- (1) For D91 see size 91; for T491 see 490, etc.
- (2) Preliminary tightening - snug all headbolts in the sequence shown. First torquing - torque all headbolts in the sequence shown to the listed value.
- (3) Retorque to the listed value after 2 - 5 hours running time.

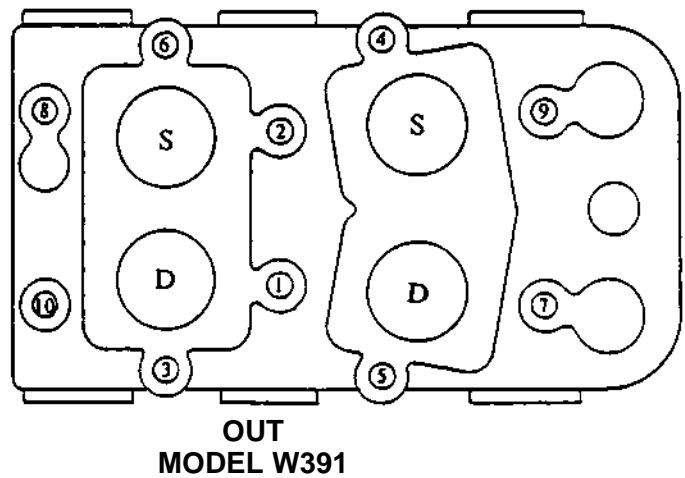
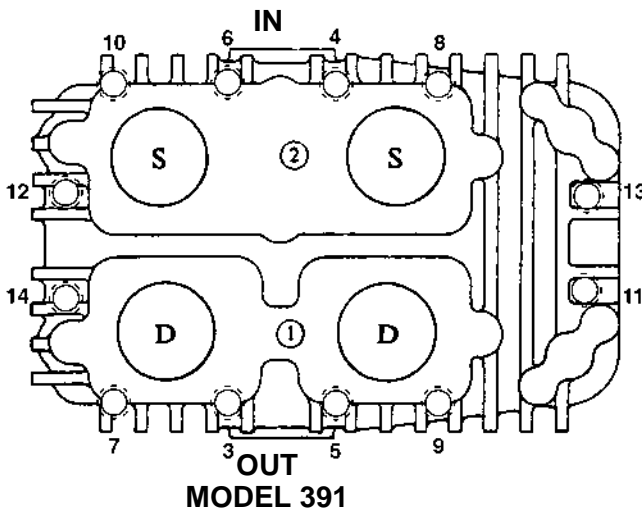
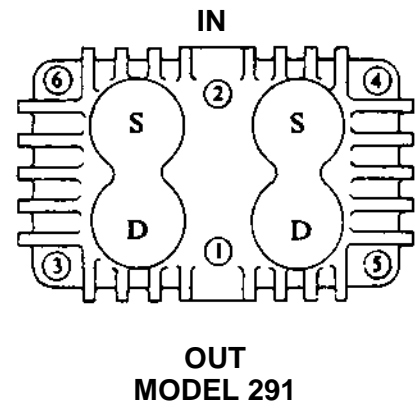
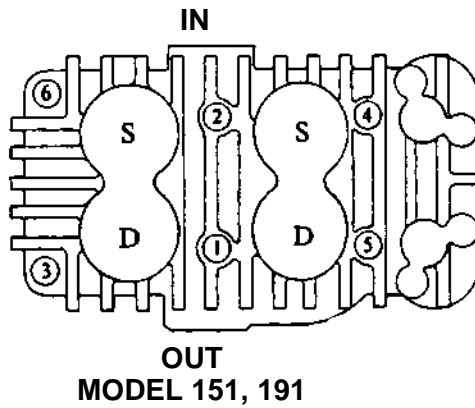
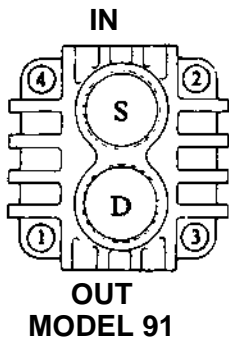

**APPENDIX D**

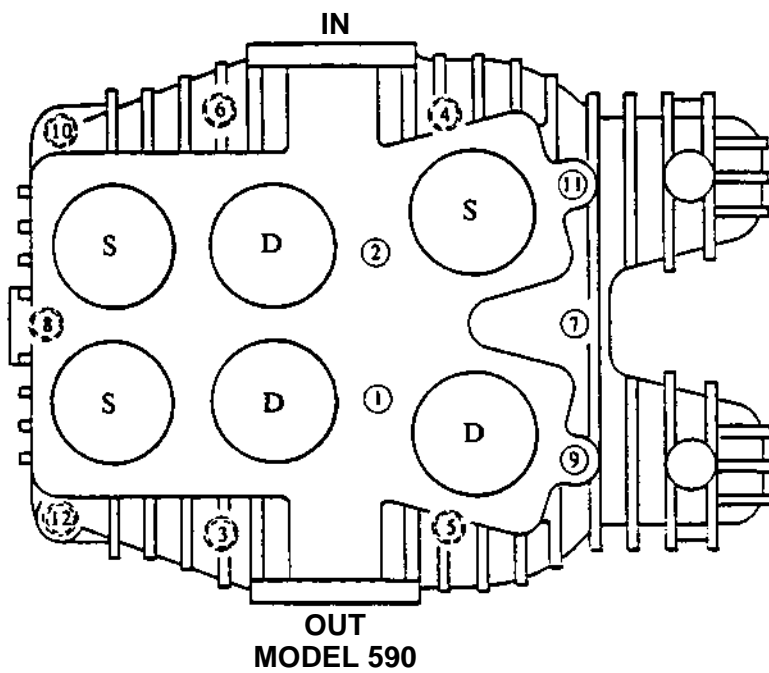
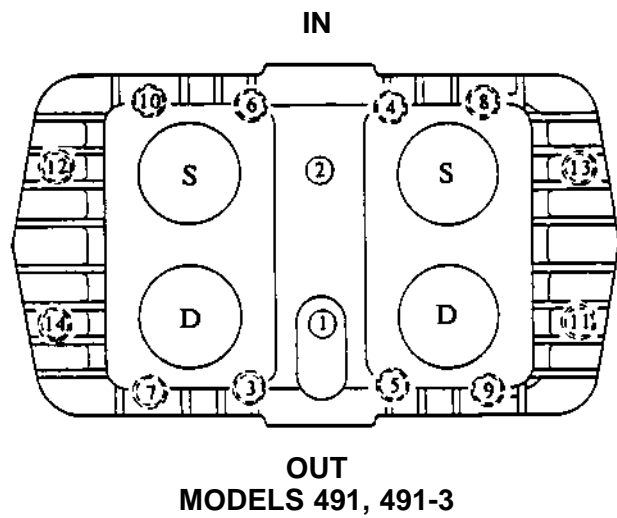
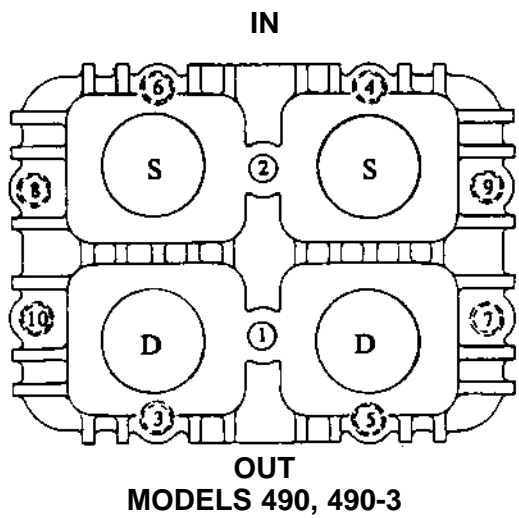

- - BOLT FROM TOP
- ⊗ - BOLT FROM BOTTOM

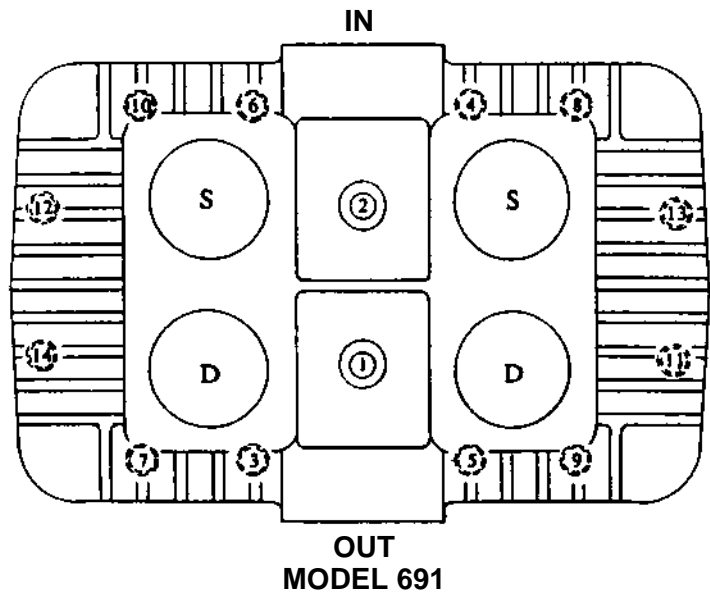
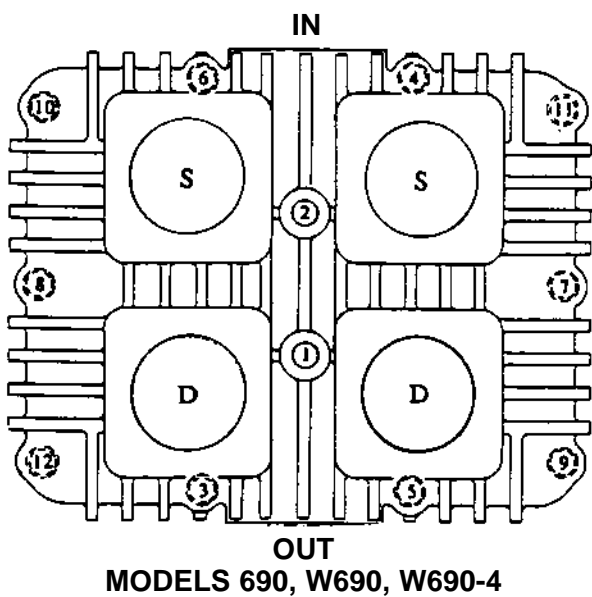

## CLEARANCES AND DIMENSIONS

All Dimensions are in Inches

	91	191		291	391		491	491-3	591M		691M	691-4M
		St. 1	St. 2		St. 1	St. 2			St. 1	St. 2		
Clearance:												
Conrod bearing to crankshaft journal	0.0005 0.0025	0.0005 0.0025	0.0005 0.0025	0.0005 0.0025	0.0005 0.0025	0.0005 0.0025	0.0005 0.0025	0.0005 0.0025	0.0005 0.0025	0.0019 0.0035	0.0019 0.0035	0.0019 0.0035
Clearance:												
Wrist Pin to Wrist-Pin Bushing* (max)	0.0009	0.0009	0.0009	0.0009	0.0009	0.0009	0.0009	0.0009	0.0020	0.0020	0.0020	0.0020
Cylinder Borer Diameter (max)	3.009	3.009	1.756	3.009	4.515	2.508	4.011	3.009	6.015	3.259	4.515	4.011
Cylinder Finish (RMS)	16-32	16-32	16-32	16-32	16-32	16-32	16-32	16-32	16-32	16-32	16-32	16-32
Piston Ring Radial Thickness (min)	0.082	0.054	0.082	0.082	0.093	0.082	0.082	0.082	0.090	0.152	0.082	0.082
Clearance:												
Oil-Pump Adapter Shaft to Bushing* (max)	0.0050	0.0050	0.0050	0.0050	0.0050	0.0050	0.0050	0.0050	0.0050	0.0050	0.0050	0.0050
Crankshaft End Play (Cold)	0.002 0.003	0.002 0.003	0.002 0.003	0.002 0.003	0.002 0.003	0.002 0.003	0.002 0.003	0.002 0.003	0.002 0.003	0.002 0.003	0.002 0.003	0.002 0.003
Flywheel Runout at O.D. (max)	0.020	0.020	0.020	0.020	0.020	0.020	0.020	0.020	0.020	0.020	0.020	0.020
Clearance:												
Crosshead to Crosshead Guide Bore (max)	.011	.011	.011	.011	.012	.012	.012	.012	.013	.013	.013	.013
Crosshead Guide Bore Finish (max)	32 RMS (Limited number of small pits and scratches are acceptable)											

\* Dimensions for honing are included with new bushings (which must be installed, then honed).

## PISTON CLEARANCE "X" (COLD)

(See Figures 5.4A and 5.4B)

### PISTON CLEARANCE (COLD)

MODEL	"X" INCHES (MILLIMETER)	
	Minimum	Maximum
91, 191, 291, 491 (b)	.020 (.51)	.044 (1.12)
A91, D91, A191, D191, A291, D291, WA391, WD391, D491 (b), 491-3 (b), D391, D491-3, FD151	.025 (.64)	.049 (1.24)
T690-4, WT690-4, WT690, WT590, T590	.100 (2.54)	.112 (2.84)
T691	.115 (2.92)	.127 (3.22)
190, 390, 490, 491 (a)	.000 (.00)	.024 (.61)
A190, D190, A390, D390, A490, D490, D491, D490-3	.005 (.13)	.029 (.74)
T491, T490-3	.010 (.25)	.034 (.86)
WT391, T491 (b), T491-3, T191, T291, T91	.030 (.76)	.054 (1.36)
590, 690, W690	.000 (.00)	.012 (.30)
691	.015 (.38)	.027 (.68)
A590, WA590, A690, WA690	.045 (1.14)	.057 (1.45)
D590, WD490, D690, DD690-4, WD690, WD690-4	.050 (1.27)	.062 (1.57)
D691, D691-4	.065 (1.65)	.077 (1.95)

#### NOTES:

- (a) For 491 Compressors with flat gasket.
- (b) For 491 Compressor with O-rings.

**CAUTION: ALWAYS RELIEVE PRESSURE IN THE UNITS BEFORE ATTEMPTING ANY REPAIRS.**

## APPENDIX E

PURGING AND DRAINING OF DISTANCE PIECE AND PISTON ROD PACKING ORIENTATION

MODEL	CONDITIONS	SERVICE	DISTANCE PIECE OPENING, 1/4 INCH NPT		V-RINGS POINT	
			UPPER	LOWER	UPPER	LOWER
D91A, D191A, D290A, D291A, D390A, WD391A, D490A, D490-3A, D491A, D590A, WD590A, D690A, D691A, D690-4A, WD690A, WD590-4A	Inlet pressure: Above 15 psia	1) General gas transfer	Plugged to allow the distance piece pressure to reach its own level.	Pipe to drain or vent with a shut-off valve. Distance piece must be drained weekly to prevent an accumulation of oil or condensate.	SPRING	SPRING
		2) Highly toxic gases	Pressurized via an external gas source to a pressure below suction pressure and above atmospheric pressure. Or, vented to atmospheric pressure (at a suitable location) or to a low-pressure flare.			
D191B, D390B, WD391B, D590B, WD590B	Inlet pressure: limited vacuum to 25 psia or distance piece pressure greater than Inlet pressure	General gas transfer or evacuation	Pressurized via an external gas source to a pressure above interstage pressure. Or, tubed to second-stage inlet.		SPRING	SPRING
D91B, D191E, D290B, D291B, D390E, WD391E, D490B, D491B, D590E, WD590E, D690B, D691B, WD690B	Inlet pressure: 3 psia to 25 psia	General gas transfer or evacuation	Pressurized via an external gas source to a pressure above discharge pressure. Or, tubed to compressor discharge.	Pipe to drain or vent with a shut-off valve. Distance piece must be drained weekly to prevent an accumulation of oil or condensate.	SPRING	SPRING
D91D, D191D, D290D, D291D, D390D, WD391D, D490D, D491D, D590D, WD590D, D690D, D691D, WD690D	Inlet pressure: 15 psia to 50 psia	Oxygen transfer	None - Distance piece milled open	None	SPRING	SPRING

T91G, T191/291G, T391/491G

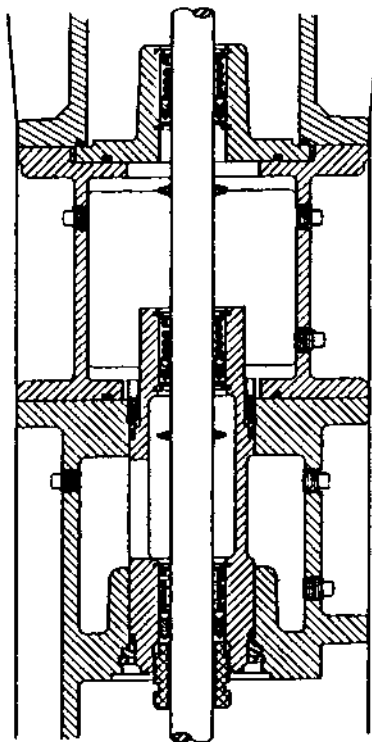

General gas transfer - all distance piece openings are plugged to allow d-pieces to reach their own pressure level.  
Optional - connect any of the d-piece openings to an atmospheric vent (at an appropriate location) or low-pressure flare.

Lowered-piece purge should be an inert gas at a pressure slightly greater than compressor suction pressure. The top d-piece pressure is maintained by a needle valve or regulator at a pressure lower than the compressor suction pressure.

T91H, T191/291H, T391,491H

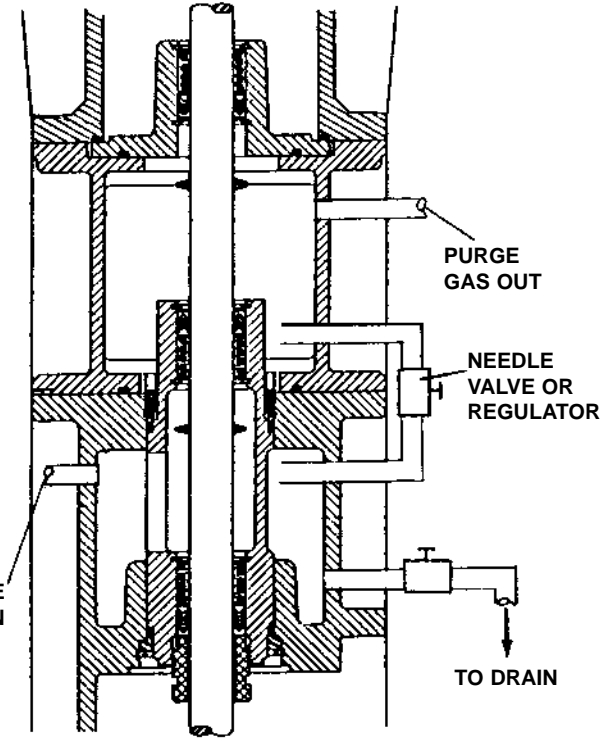

APPENDIX F

## COMPRESSOR TROUBLE SHOOTING

### GENERAL

In most cases problems with your Corken Gas Compressor can be solved quite simply. This chart lists some of the more frequent problems that occur with reciprocating compressors along with a list of possible causes. If you are having a problem which is not listed or if you cannot find the source of the problem, consult the factory.

PROBLEM	POSSIBLE CAUSE
Low capacity	1, 2, 3, 4, 17
Overheating	1, 2, 3, 5, 6, 11, 16
Knocks, rattles and noise	1, 7, 9, 10, 11, 15
Oil in cylinder	8, 12, 15
Abnormal piston-ring wear	1, 3, 5, 6, 11, 15, 16
Product leaking through crankcase breather	8, 15
Product leakage	4, 8, 15, 17
Oil leakage around compressor base	18, 19
No oil pressure	20, 21
Excessive vibration	1, 7, 9, 10, 11, 13, 14, 29
Motor overheating or starter tripping out	22, 23, 24, 25, 26, 27, 28, 29

REF.	POSSIBLE CAUSES	WHAT TO DO
1.	Valves broken, stuck or leaking	Inspect and clean or repair
2.	Piston ring worn	Inspect and replace as necessary
3.	Inlet strainer clogged	Clean or replace screen as necessary
4.	Leaks in piping	Inspect and repair
5.	Inlet or ambient temperature too high	Consult factory
6.	Compression ratio too high	Check application and consult factory
7.	Loose flywheel or belt	Tighten
8.	Worn piston-rod packing	Replace
9.	Worn wrist pin or wrist-pin bushing	Replace
10.	Worn connecting-rod bearing	Replace
11.	Unbalanced load	Inspect valve or consult factory
12.	Oil in distance piece	Tighten packing nut - drain weekly
13.	Inadequate compressor base	Strengthen, replace or grout
14.	Improper foundation or mounting	Tighten mounting or rebuild foundation
15.	Loose valve, piston or packing	Tighten or replace as necessary
16.	Dirty cooling fins	Clean weekly
17.	4-way control valve not lubricated	Inspect and lubricate
18.	Leaking gas blowing oil from crankcase	Tighten packing
19.	Bad oil seal	Replace
20.	No oil in crankcase	Add oil
21.	Oil-pump malfunction	See oil-pressure adjustment
22.	Low voltage	Check line voltage with motor nameplate. Consult power company
23.	Motor wired wrong	Check wiring diagram
24.	Wire size too small for length of run	Replace with correct size
25.	Wrong power characteristics	Voltage, phase and frequency must coincide with motor nameplate. Consult with power company
26.	Wrong size of heaters in starter	Check and replace according to manufacturer's instructions
27.	Compressor overloading	Reduce speed
28.	Motor shorted out	See driver installation
29.	Bad motor bearing	Lubricate according to manufacturer's instructions

### TWO-STAGE COMPRESSOR TROUBLE-SHOOTING

Two-stage compressors can have problems that never occur with single-stage machines. Interstage pressure is an important indicator of the condition of a two-stage compressor.

Interstage pressure is too high:

1. Second-stage valves may be broken or leaking.
2. Second-stage piston rings may be worn.

Interstage pressure is too low:

1. First-stage valves may be broken or leaking.
2. First-stage piston rings may be worn.

Another cause of high interstage pressure is a low compression ratio. Two-stage machines should not be used in applications where the compression ratio is below 5. To use two-stage compressors in this kind of situation results in rapid ring wear, machine imbalance and excessive horsepower. If you think you have a problem in this area, consult the factory.

## APPENDIX G

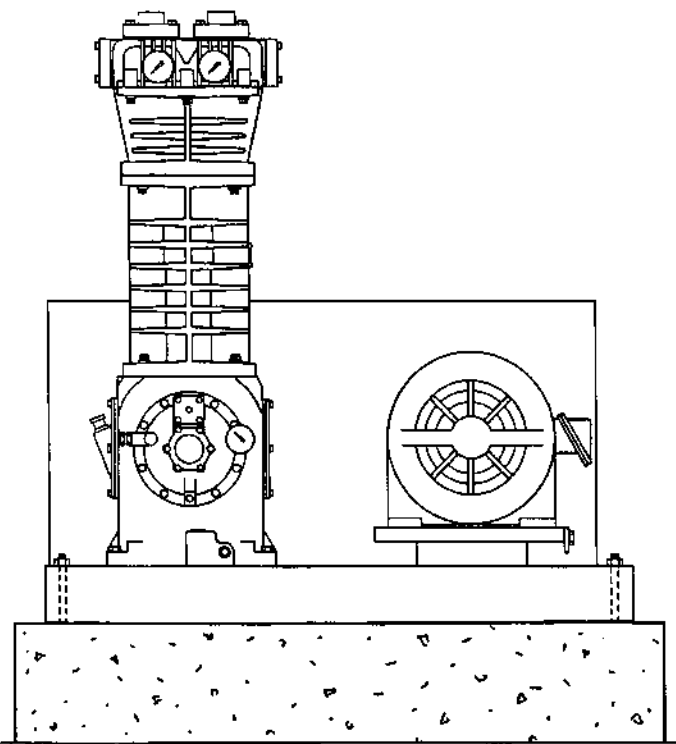

Corken Vertical Compressors are similar in many ways to the small vertical lubricated compressors that have been used for years. However, Corken Oil-Free Compressors are, by design, much taller than most other compressor types. This also means that the vertical center of gravity is considerably higher. These factors amplify the magnitude of any vibration present, and must be considered when selecting a mounting location for your compressor.

Corken recommends that all installation be provided with a concrete pad or sturdy structural steel mounting base.

Most Corken units do fine with the baseplate mounted directly to a solid reinforced concrete slab. Special attention should be given to the large vertical compressors (models 590, 690, 791, and 891). These units require very firm foundations due to their vertical height. The HG 600 series is a horizontal balanced-opposed unit, but we suggest that the same foundation guidelines be followed.

Generally speaking, the larger the foundation, the less likely you are to have vibration or shaking problems.

Permanent anchor bolts or "J" bolts embedded in the foundation will usually provide excellent stability. Grouting the baseplate into your foundation and checking the mounting bolts for tightness at frequent intervals is highly recommended.

As a rule of thumb, when preparing the foundation, the mounting slab should be a minimum of 8 inches thick, with the overall length and width 4 inches longer and wider on each side of the baseplate.

The following illustrations show some basic guidelines to follow. The mounting variations shown are guidelines only. A properly engineered foundation should be installed before putting your new compressors into service. A special baseplate is required on some of the illustrations.

### IMPORTANT

Any proposed isolation mounting arrangement must be properly engineered. Failure to do so will most likely increase the severity of the problem.

The compressor must not support any significant piping weight. The piping must be properly supported. The use of flexible connections at the compressor is highly recommended. Rigid, unsupported piping combined with a poor foundation will result in severe vibration problems.

Corken baseplates come with anchor-bolt mounting holes. Use all mounting holes when installing baseplates.

If you have any questions about the compressor foundation for your installation, please feel free to contact Corken.

## APPENDIX H

1. NO

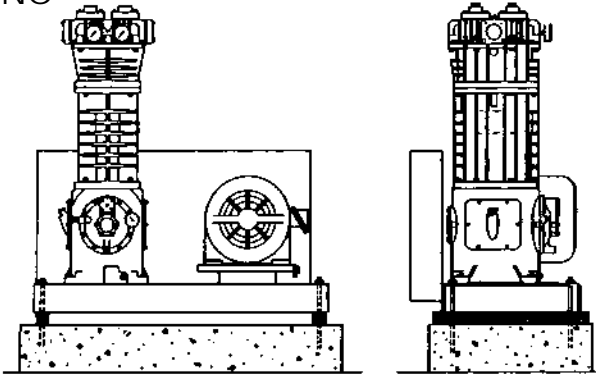

Do not suspend baseplate with spacers or shims allowing support only at the anchor bolts.

2. YES

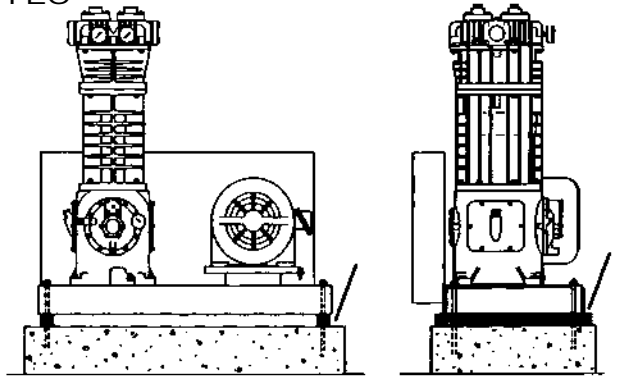

Support entire length of base to slab. Some shims may be required on an unlevel slab.

3. NO

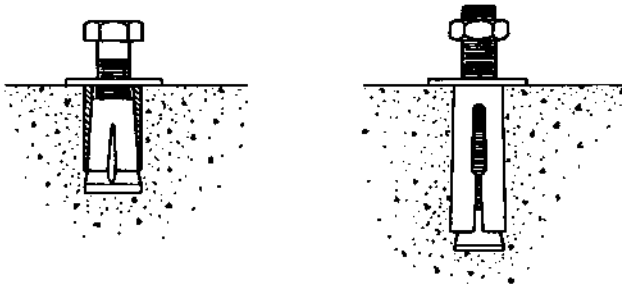

Lead anchors will not hold permanently.

If anchors must be used, they should be the type with a steel stud and sleeve.

4. YES

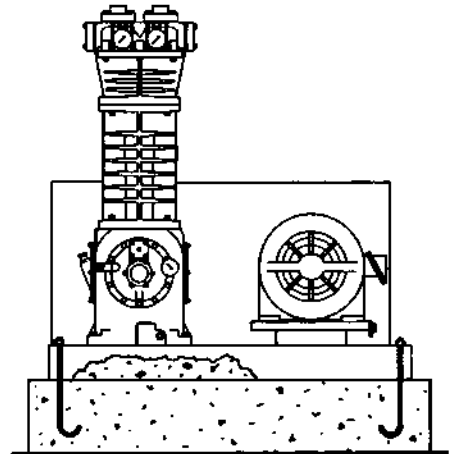

Permanent anchor bolts imbedded in concrete slab is a very good installation method. Grouting the baseplate to the slab is highly recommended.

5. NO

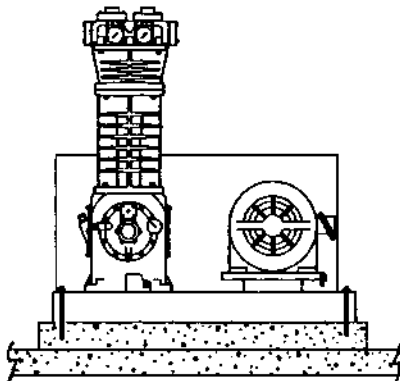

Anchors or lags with a shallow mounting will pull loose. Be sure the existing floor is solid. (Special consideration should be given to units on suspended floors.)

6. YES

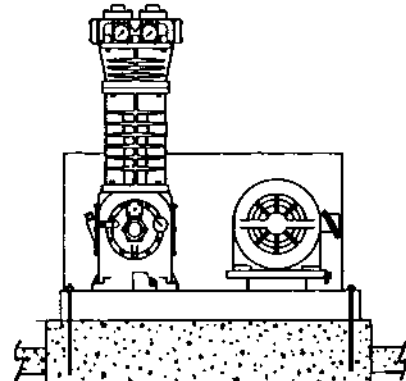

If the existing floor is too weak to support compressor mounting, cut out existing floor and mount a separate foundation directly on the ground.

APPENDIX H

7. NO

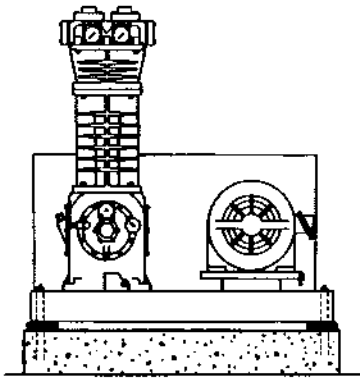

Rubber mounts or pads are generally not recommended.

8. YES

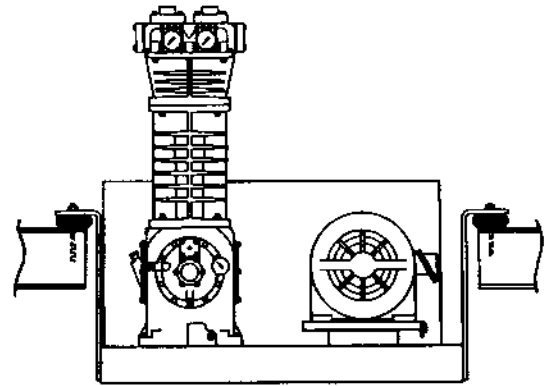

NOTE: A special rigid baseplate is required on this mounting. Installing mounts at the compressor's center of gravity is effective on smaller units (models 90 - 490).

9. NO

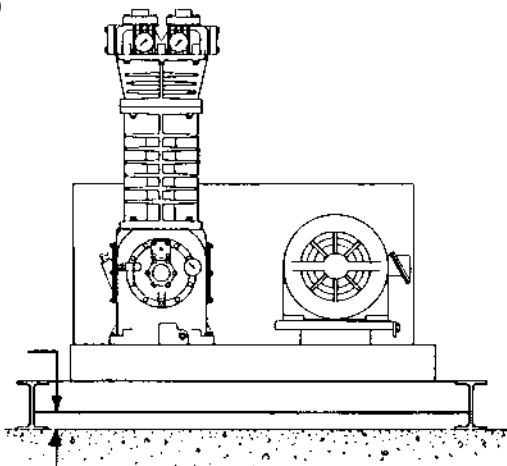

If skid mounting, do not mount the compressor assembly on shallow beams or angle iron.

10. NO

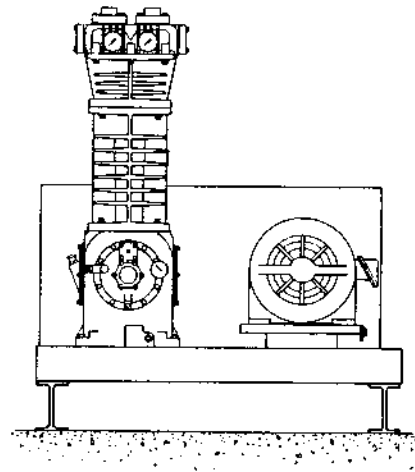

Do not mount the compressor assembly across beams without center support.

11. YES

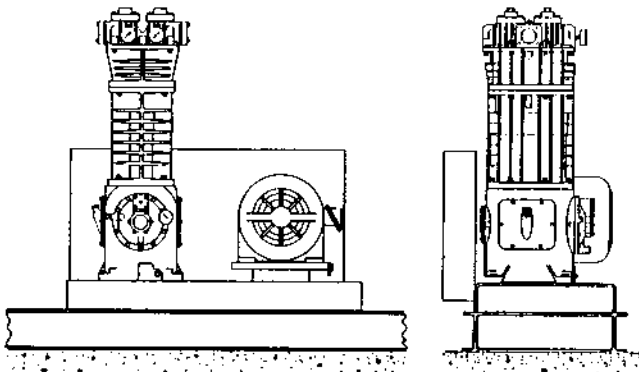

Mount the baseplate so that the beam or channel provides support along the entire length of the baseplate. NOTE: Crossbeams should be full depth of main beams. The baseplate is normally welded to the skid directly over the vertical web of the support beam.

12. YES

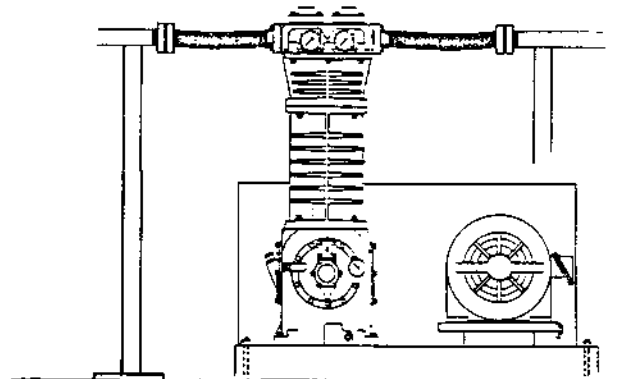

The compressor must not support any significant piping weight. The piping must be properly supported. The use of flexible connections at the compressor is highly recommended. Rigid, unsupported piping combined with a poor foundation will result in severe vibration problems.

APPENDIX H



*Solutions beyond products...*

**CORKEN**<sup>®</sup>  
**IBEX**

P.O. Box 12338, Oklahoma City, OK 73157  
3805 N.W. 36th St., Oklahoma City, OK 73112  
Phone (405) 946-5576 • Fax (405) 948-7343  
E-mail [corken@corken.com](mailto:corken@corken.com)  
Web address [www.corken.com](http://www.corken.com)