



Petroleum Pumps

PS-Series and PT-Series Pumps for Refined
Petroleum Products and Industrial Solvents



LIQUID CONTROLS GROUP
IDEX

Your Single Source for Stationary & Transportation Solutions...

Another choice in petroleum pumps...

The Liquid Controls Group PS-Series and PT-Series petroleum pumps offer the industry another choice in pump brand for greater flexibility and independence in the configuration and installation of fluid transfer systems and fuel delivery vehicles. The pumps match common industry-standard flange-to-flange and mounting foot print dimensions for easy incorporation into existing or new vehicle layouts. They provide features that will be appreciated by system designers, delivery truck fabricators, and end-user fuel marketers.

Multi-product package offering...

Common corporate ownership and shared distribution make it possible for customers to combine system components including pump, meter, and register in a single order to greatly simplify the procurement process. In terms of ease of doing business, product functionality, and breadth of product offering, Liquid Controls Group is your single source solution for transporting, dispensing and controlling high value fluids and gases.

Three pump sizes available...

Available in 2, 2.5 and 3 inch flange sizes. Flow rates range from 31 to 271 gpm (117 to 1,026 L/min) and differential pressures up to 125 psi (8.6 bar).

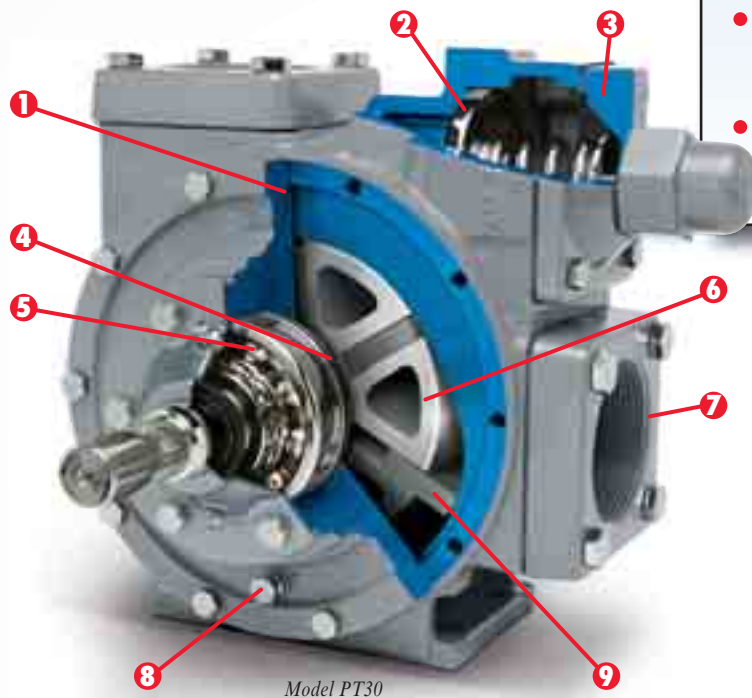

Model PT30

Features of the PS-Series and PT-Series

- 1 O-ring design delivers maximum sealing capability and is available with optional seal materials.
 - 2 Corrosion resistant bypass valve made of nickel plated cast iron.
 - 3 Available with a standard bypass valve or an optional air operated valve (AOV) for high and low flow control. Additionally, the AOV relieves the pressure in the lines for easier handling of the hose nozzle.
 - 4 Reliable mechanical seal design with optional seal materials.
 - 5 Heavy duty ball bearings provide greater durability and strength.
 - 6 Hollow rotor helps reduce weight.
 - 7 Available with T-style strainers that help keep your pumping system free from damage caused by welding slag and foreign materials left in piping and tanks.
 - 8 Conveniently located drain plug allows you to empty the pump quickly when necessary.
 - 9 Positive displacement sliding vane design delivers higher pumping efficiency and a lower noise level. The self adjusting vanes compensate for wear and extend the life of the pump.
- Installation is simple since the PS-Series and PT-Series pumps are dimensionally interchangeable with the competition.
 - Optional Viton^{®1} elastomers ensure compatibility with a wider range of fluids such as biodiesel and ethanol blends.

¹Viton[®] is a registered trademark of the DuPont company.

Pump Accessories



Optional Air Operated Valve (AOV)



Optional T-style Strainer

For Refined Petroleum Products & Industrial Solvents

Liquid Controls Group offers a wide range of products for transporting, dispensing, and controlling high value fluids and gases. These products include the following:

- Pumps
- Meters
- Valves
- Registers
- Electronics
- In cab data management systems
- Inventory control systems



Applications Include

- Fuel oil deliveries
 - Fleet refueling
 - Lube oil deliveries
 - Aviation refuelers
 - Bulk transfer
 - Bulk loading & blending
- Transporting the following:
 - Petro chemicals
 - Gasoline
 - Biofuels
 - Ethanol
 - Solvents

Model PT20

The model PT20 petroleum pump is ideal for “lube oil” deliveries that require low flow rates. Applications include deliveries to service centers such as auto dealerships and quick lube companies.



Model PT20

Model PT25

The model PT25 petroleum pump is suited for gasoline, diesel, fuel oil and other delivery vehicles. The flow rates are perfect for delivering home heating fuel and gasoline and diesel to farms and companies with fleet fueling requirements.



Model PT25

Model PT30

For quick deliveries of large flow transport applications, the PT30 is designed for fast loading and unloading applications required by bulk delivery companies. Bulk deliveries include aviation fuels, gasoline, diesel, ethanol, biodiesel and many more.



Model PT30

Maximum Specifications Chart

Model	Flow	Pump Speed	Viscosity	Differential Pressure	Working Pressure	Temperature
	GPM (L/min)	RPM	SSU (cP)	psi (bar)	psi (bar)	°F (°C)
PS/PT20	88 (333)	780	20,000 (4,250)	125 (8.6)	200 (13.8)	300 (149)
PS/PT25	159 (602)	780	20,000 (4,250)	125 (8.6)	200 (13.8)	300 (149)
PS/PT30	271 (1,026)	640	20,000 (4,250)	125 (8.6)	200 (13.8)	300 (149)

Performance Data

Model	PS/PT20		PS/PT25		PS/PT30	
RPM	520	640	520	640	520	640
GPM (L/min)	58 (220)	72 (273)	98 (371)	120 (454)	211 (799)	263 (995)
HP (kW)	2.5 (1.9)	3.0 (2.2)	3.8 (2.8)	5.0 (3.7)	7.8 (5.8)	9.5 (7.1)

Capacities and horsepower are based on a 100 SSU (22 cP) fluid at 50 psi (3.4 bar) delivered pressure.

Refer to performance curves in the PS-Series and PT-Series sales catalog or the installation, operation and maintenance (IOM) manual for flow rates at other pressures.

Outline Dimensions (all dimensions in inches and centimeters)

Model	A	B	C	D	E	F	G	H	I	J	K	L
PS/PT20	1.125 Dia. (2.86)	5.18 (13.16)	4.00 (10.16)	3.63 (9.22)	0.81 (2.06)	0.81 (2.06)	1.75 (4.45)	1.75 (4.45)	8.00 (20.32)	8.00 (20.32)	6.08 (15.44)	1.50 (3.81)
PS/PT25	1.125 Dia. (2.86)	6.64 (16.87)	4.00 (10.15)	3.63 (9.22)	1.50 (3.81)	1.50 (3.81)	2.45 (6.21)	2.45 (6.21)	9.45 (23.99)	8.75 (22.23)	6.80 (17.27)	1.75 (4.45)
PS/PT30	1.125 Dia. (2.86)	6.93 (17.60)	5.38 (13.70)	4.25 (10.80)	1.25 (3.20)	1.25 (3.20)	2.19 (5.60)	2.19 (5.60)	9.63 (24.40)	9.63 (24.40)	8.60 (21.80)	2.50 (6.40)

Model	M	N	O	P	Q	R	S	T	U	V	W
PS/PT20	4.98 (12.66)	4.13 (10.48)	0.50 (1.27)	0.44 Dia. (1.12)	2.50 (6.35)	2.50 (6.35)	3.31 (8.40)	3.31 (8.40)	3.90 (9.92)	3.90 (9.92)	5.30 (13.46)
PS/PT25	6.35 (16.12)	5.06 (12.86)	0.25 (0.64)	0.44 Dia. (1.12)	2.75 (6.99)	2.75 (6.99)	3.50 (8.89)	3.50 (8.89)	4.31 (10.95)	3.87 (9.87)	6.05 (15.36)
PS/PT30	6.44 (16.40)	5.31 (13.50)	0.75 (1.90)	0.63 Dia. (1.58)	3.00 (7.60)	3.00 (7.60)	3.63 (9.20)	3.63 (9.20)	5.00 (12.70)	4.95 (12.60)	6.43 (16.33)

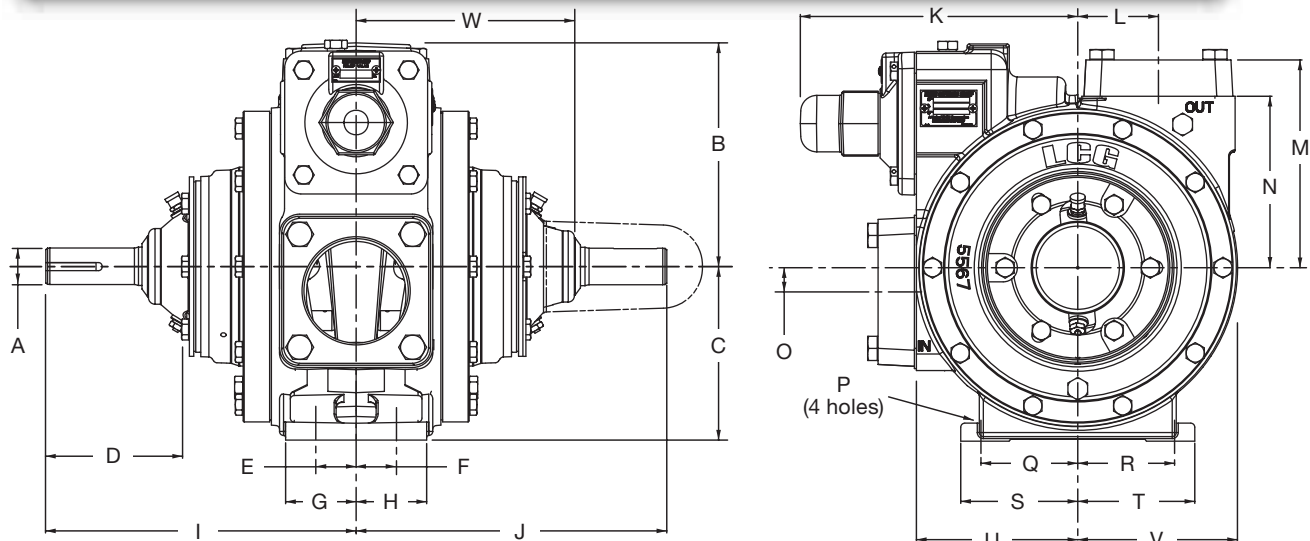

Corken Liquid Controls India
 Faure Herman Liquid Controls Sponsler
 Liquid Controls SAMPI
 Liquid Controls Europe Toptech Systems

CORKEN, INC.
 3805 N.W. 36th St., Oklahoma City, OK 73112
 (405) 946-5576 • FAX (405) 948-7343
<http://www.corken.com> • info.corken@idexcorp.com

LIQUID CONTROLS
 105 Albrecht Drive, Lake Bluff, IL 60044-2242
 1-800-458-5262 • (847) 295-1050 • FAX (847) 295-1057
<http://www.liquidcontrolsgroup.com> • lc-info.lcmeter@idexcorp.com